



New solutions for HVAC... Problem-free

DEAERATORS AND DIRT SEPARATORS



INDEX

Air in Heating and Cooling Water Systems	01	
Dirt in Heating and Cooling Water Systems	02	
Vacuum Degassers	04	ViRADEG
SCREWED PRODUCT RANGE	07	
Automatic Air Vent	08	ViRATOP
Automatic Air Vent	08	ViRASOLAR
Deaerator	10	ViRAVENT
Air Separator "Vertical"	12	ViRAVENT
Dirt Separator	14	ViRAVENT
Dirt Separator "Vertical"	16	ViRACLEAN
Steel Separators Product Range	19	
Deaerator	20	ViRAVENT
Dirt Separator	22	ViRACLEAN
Deaerator and Dirt Separator	24	ViRAPLUS
Deaerator, Dirt and Hydraulic Separator	26	ViRAFIX
Hydraulic Balance Tank	28	ViRABALANCE
Magnetic Product Range	31	
Dirt Separator "Magnetic"	32	ViRACLEAN
Deaerator and Dirt Separator "Magnetic"	34	ViRAPLUS
Deaerator, Dirt and Hydraulic Separator "Magnetic"	36	ViRAFIX
Chemical Dosing Pots	38	ViRADOSING
Sizing	40	
Pressure Drop	41	

The Problems Caused by Air

Air in heating and cooling systems causes the following problems:

- Noise in radiators, heat exchangers, pipes and pumps,
- Rapid wear and tear of heat exchangers, controllers, shut-off valves and pumps,
- Insufficient heat emission or cooling efficiency, reduced heat transfer,
- Increased energy consumption,
- Needing to deaerate by hand,
- Higher maintenance costs,
- Corrosion,

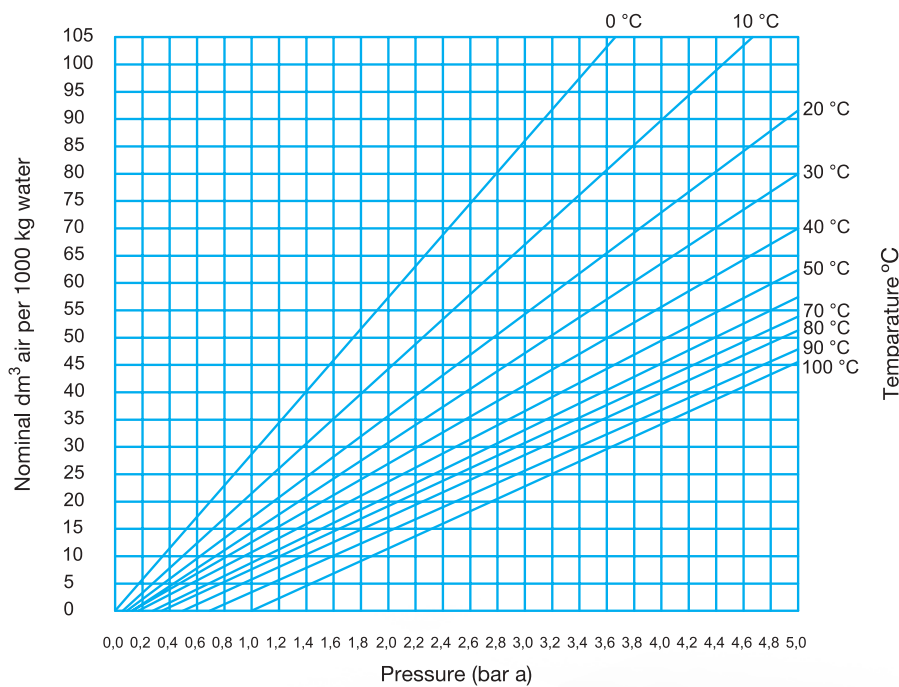

Graphic 1

Occuring and Source of Air in System

- Air is present before filling the system and trapped in the system when filled.
- Air is entrained in mains water when filling the system.
- Air dissolved in water is released when the temperature rises or the pressure falls during system runs. (Graphic 1)

Air in Heating System

The amount of air which is dissolved in water, is dependent on both temperature and pressure. Air dissolved in water is released when the temperature rises or the pressure falls. (Graphic1) Releasing of micro bubbles takes place continuously in the boiler and in any device which operates under conditions of cavitation. When high temperatures occur at the combustion chamber wall of the boiler, small air bubbles are released from water containing air. (Figure1) Micro bubbles should be removed immediately upon leaving the boiler.

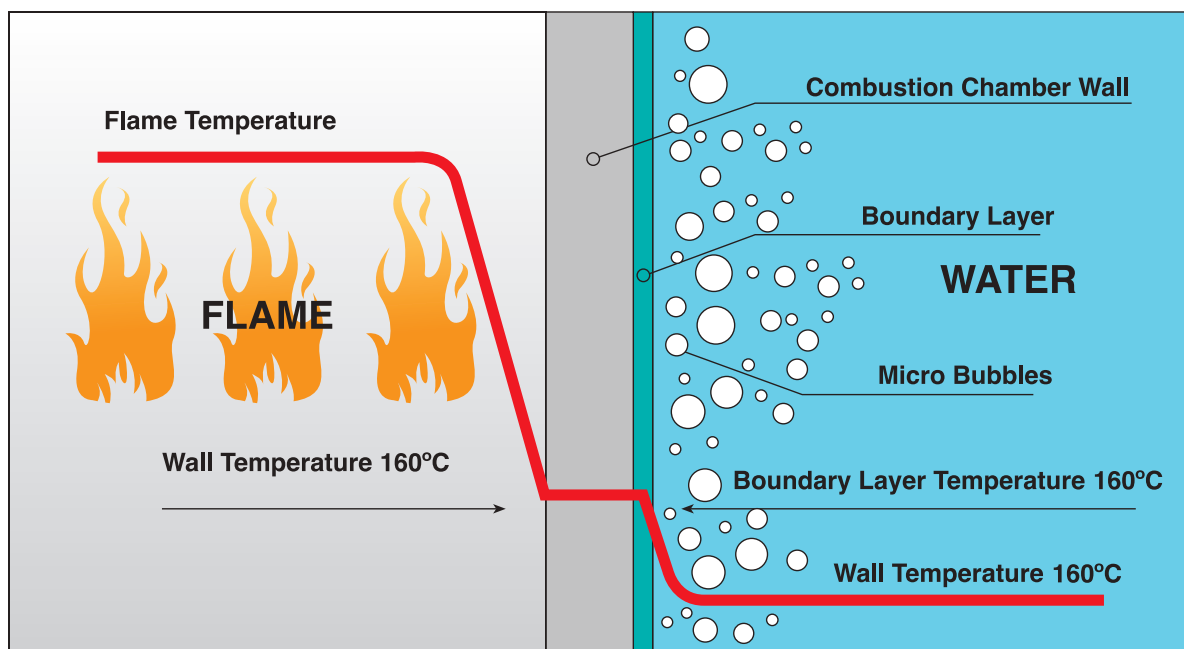

Figure 1

Air in Cooling System

In cooling systems part of the air is dissolved in water and some part is air bubbles. Pressure has the largest influence on the formation of air bubbles in a cooling system.

After decreasing the temperature of water in the coil, part of the air bubbles will again dissolve in the water. To prevent air bubbles causing pump damage due to cavitation, air bubbles should be released before the pump.

The Problems Caused by Dirt

Dirt in heating and cooling systems causes the following problems:

- Increased system noise,
- Heat exchangers, boilers and radiators can become obstructed both impeding the flow of water and reducing the heat transfer,
- Strainers becoming blocked causing increased pressure drops hence additional pumping costs or loss of capacity,
- Pump seals will be exposed to the scouring effect of the particules in the water and will wear more quickly
- Low velocity pipework (such as underfloor heating) can accumulate debris so reducing the heat transfer surface,
- Higher maintenance costs,
- The build up of sludge and dirt in a system will reduce effective operation,

Accumulation and Source of Dirt in System

- Dirt will enter the system while it is being fabricated (eg, sand, fibres from cloths, swarf from pipe cutting and welding slag),
- Once in operation there will also be accumulation of scale and particles from corrosion – the dissolved oxygen causing the corrosion,

The reaction between iron, water and oxygen will form magnetite and if oxygen is then present, the magnetite is converted to the hematite.



VIRADEG

VACUUM DEGASSERS

TYPE : V4 - V6 - V9 - V16



Features

Type	: V4 - V6 - V9 - V16
Connection	: G 3/4"
Max. System Volume	: 25 m ³
System Pressure	: 1 - 16 bar
Max. Temperature	: 90 °C
Supply Voltage	: 230 V ± 10%/50 Hz
Absorbed Power	: 100 W
Auto - Refill	: Yes

Applications

ViradeG vacuum degassers are installed in a bypass in the main flow of heating and cooling systems. Part of the system fluid is temporarily placed in a vacuum. Gases dissolved in the fluid are released, separated and removed from the system. Reintroducing the degassed fluid into the system allows it to absorb further free air pockets from the circuit. Air-free installation fluid ensures optimum system performance, and also greatly reduces commissioning times. Besides realising optimised system efficiency, all standard ViradeG models save extra energy thanks to the integrated SmartSwitch. This device ensures that the degasser is only operational when necessary.

Benefits;

- Removes all gases, free air, microbubbles and dissolved gases.
- Absorptive fluid also ensures the removal of trapped gas bubbles.
- Easy installation, which greatly reduces commissioning and handover.
- Energy-efficient whilst still achieving the lowest possible gas concentration thanks to SmartSwitch.
- Degassed (re)filling and sustained pressure.
- Warns before (re)filling becomes excessive.
- Two-year guarantee.



Technical Features

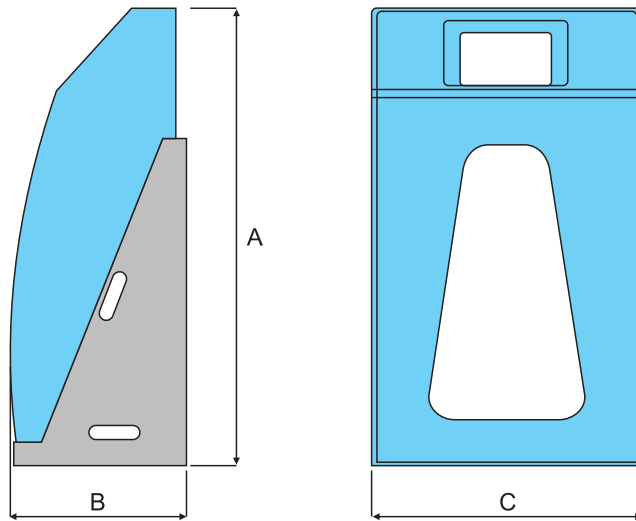

For heating and cooling systems 1 - 4.5 bar

Type	A x B X C	Max. System volume (m ³)	Temperature Range (°C)	Operating Pressure (bar)	Weight (kg)
ViraDEG V4	980 x 370 x 550	25	0 - 90	1 - 4	14
ViraDEG V4 - R	980 x 370 x 550	25	0 - 90	1 - 4	15

Max. 50% glycol

For heating and cooling systems 1 - 6 bar

Type	A x B X C	Max. System volume (m ³)	Temperature Range (°C)	Operating Pressure (bar)	Weight (kg)
ViraDEG V6	980 x 370 x 550	300	0 - 90	1 - 6	60
ViraDEG V6 - R	980 x 370 x 550	300	0 - 90	1 - 6	62

Max. 40% glycol

For heating and cooling systems 5 - 16 bar

Type	A x B X C	Max. System volume (m ³)	Temperature Range (°C)	Operating Pressure (bar)	Weight (kg)
ViraDEG V9		300	0 - 90	5 - 10	
ViraDEG V9 - R		300	0 - 90	5 - 10	
ViraDEG V16		300	0 - 90	9 - 16	
ViraDEG V16 - R		300	0 - 90	9 - 16	

Max. 40% glycol



New solutions for HVAC... **Problem-free**



Automatic Air Vent

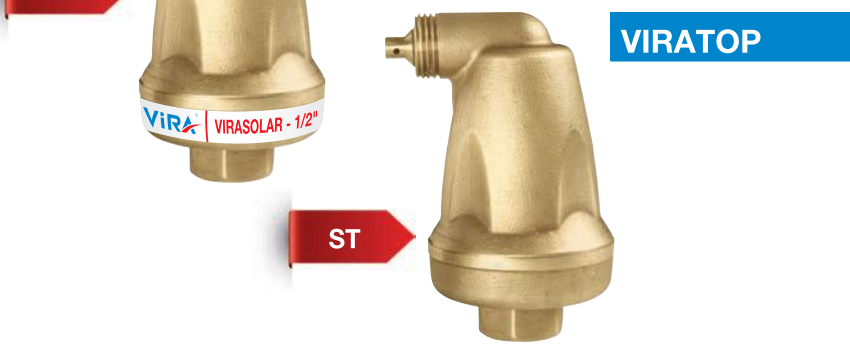

Automatic Air Vent

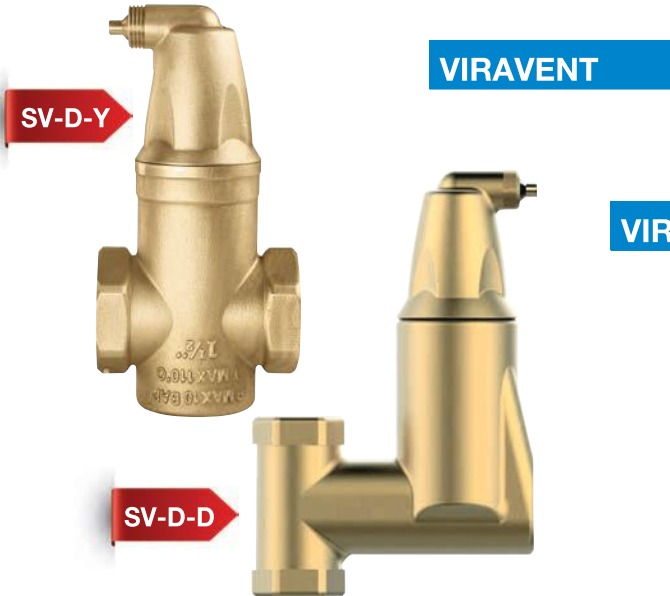

Deaerator

Deaerator

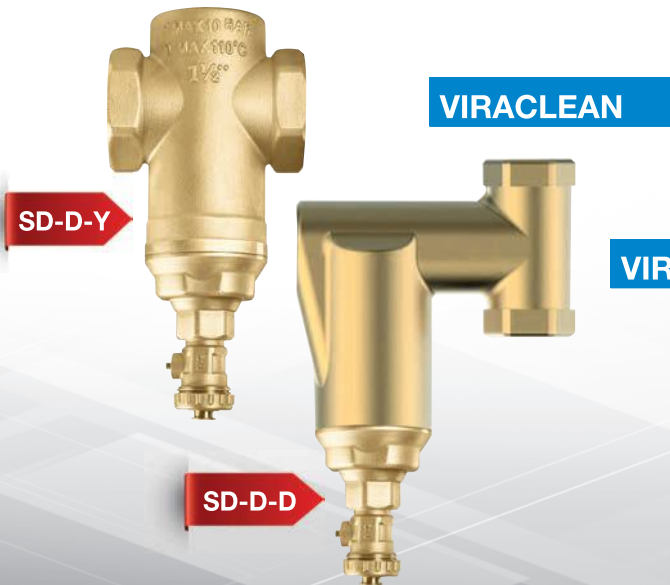

Dirt Separator

Dirt Separator

VIRATOP - VIRASOLAR

AUTOMATIC AIR VENT

TYPE : ST - SS

1/2"



Features

Smarttop

- Body : Brass
- Connections : Screwed
- Max. Working Temperature : 110 °C
- Max. Working Pressure : 10 bar
- Product Range : ST Screwed - 1/2"

Smartsolar

- Body : Brass
- Connections : Screwed
- Max. Working Temperature : 160 °C
- Max. Working Pressure : 10 bar
- Product Range : SS Screwed - 1/2"

Applications

Automatic Air Vents automatically purges air, micro bubbles and other gases from the system into the atmosphere quickly and reliably. Air can be collected at high points or specifically designated collection points. There is a float-controlled vent valve in the **VIRATOP** and **VIRASOLAR**.

If the float loses buoyancy due to the air that has accumulated in the collection chamber, it sinks and the vent valve opens. Automatically air is purged. The float has enough space to move freely even if there are dirt deposits in the air collection chamber. This waterlevel ensures to protect the valve mechanism from dirt. **VIRASOLAR** can be used for new built projects and renovation of solar installations.

Technical Features

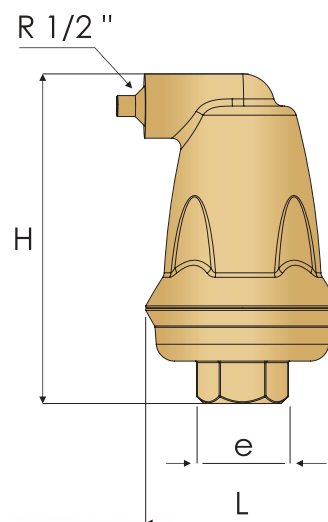

TYPE	DN	H	h	L	R	e	Weights
		mm	mm	mm	mm	inch	kg
ST	1/2"	102	-	∅ 59	1/2"	1/2"	0,54
SS	1/2"	102	-	∅ 59	1/2"	1/2"	0,64

Note : Vira, reserves the right to modify dimensions, material and design without warning.

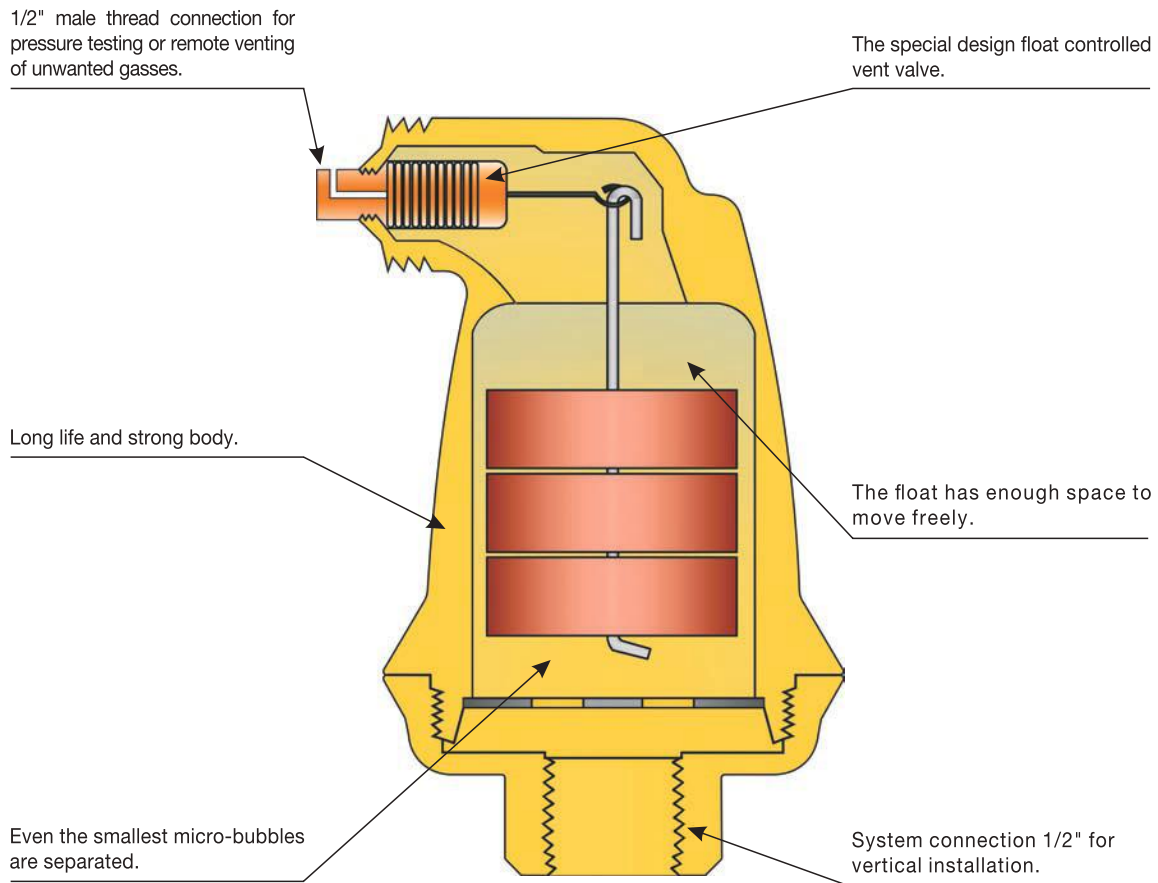

Installations

VIRATOP - VIRASOLAR Automatic Air Vent must be installed at high points or specifically designed collection points. It can be used for hard to reach areas such as the tops tanks heaters and horizontal lines near the ceiling.

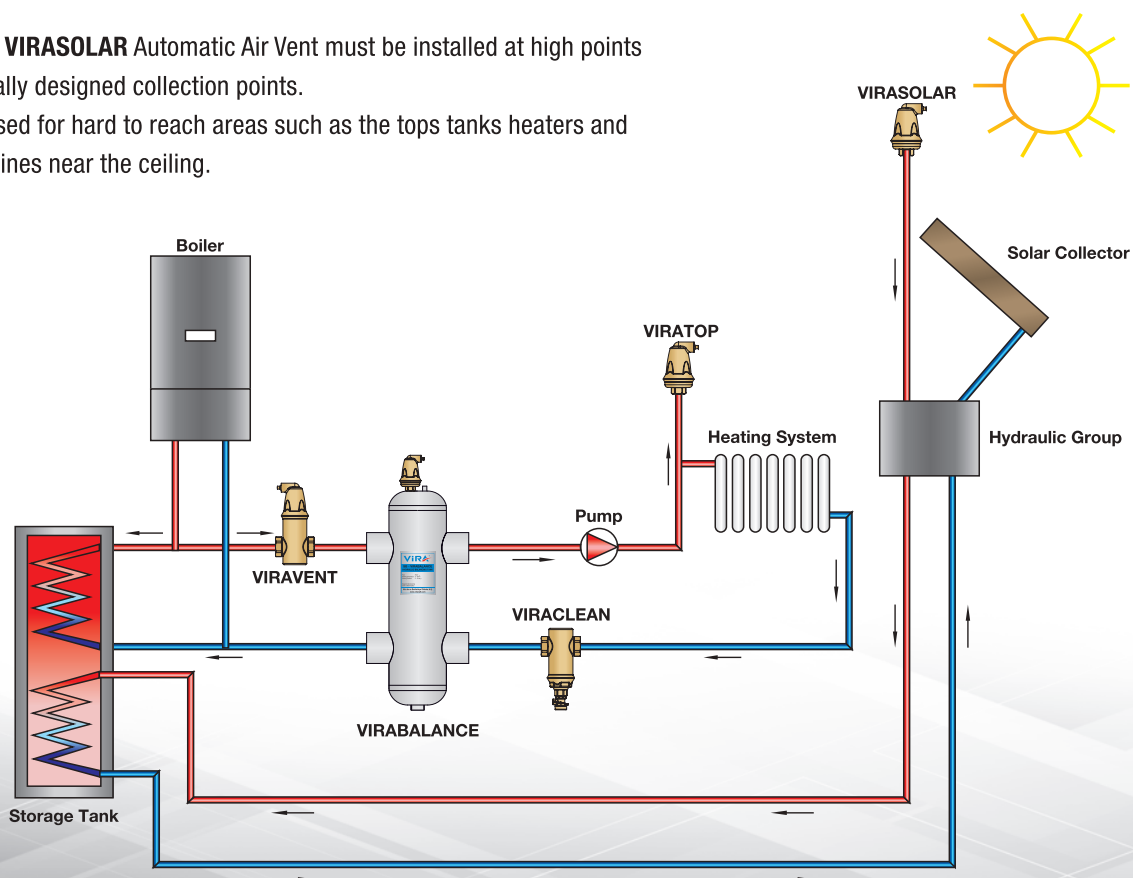

VIRAVENT DEAERATOR

TYPE : SV-D-Y

3/4" - 1" - 1 1/4" - 1 1/2" - 2"



Features

Viravent SV-D-Y

Body	: Brass
Connections	: Screwed / Horizontal
Max. Working Temperature	: 110 °C
Max. Working Pressure	: 10 bar
Strainer Screen	: Stainless Steel

Applications

VIRAVENT deaerators are used in pipelines for the high efficiency removal of air and micro bubbles from heating and cooling systems in buildings.

VIRAVENT unit must be installed at the hottest part of the systems for optimum performance.

The static head must not exceed 15 m. for heating system and 5 m. for cooling system.

The efficiency of the unit will be reduced if;

- The static head is exceeded.
- The maximum flow velocity of 3m/s is exceeded.

In a heating system the deaerator should be in the flow, preferably at the highest temperature (next to the heat source) and low pressure if possible.

Viravent deaerator should be installed after the boiler and on the pump suction side, as there are the points where the fermentation of micro bubbles is greatest.

In a chilled water system the unit must be located in the return close to the chiller.

Technical Features

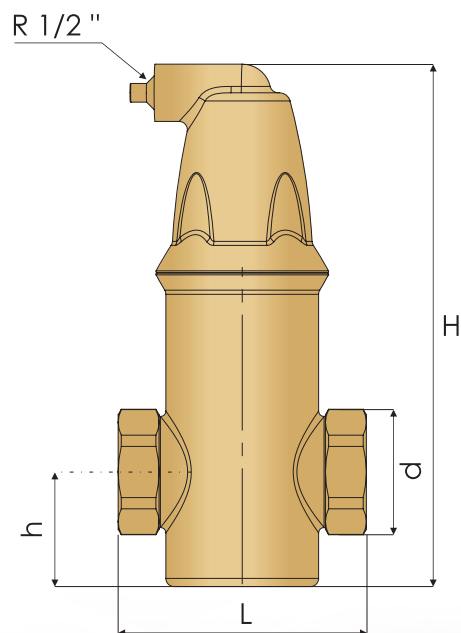

TYPE	DN	H	h	L	R	e	Weights kg
		mm	mm	mm	mm	inch	
SV-D-Y	3/4"	192	25	86	1/2"	-	1,04
SV-D-Y	1"	162	40	85	1/2"	-	0,90
SV-D-Y	1 1/4"	164	41	88	1/2"	-	0,95
SV-D-Y	1 1/2"	188	45	99	1/2"	-	1,19
SV-D-Y	2"	188	46	99	1/2"	-	1,32

Note : Vira, reserves the right to modify dimensions, material and design without warning.

1/2" male thread connection for pressure testing or remote venting of unwanted.

With the special design air vent no leakage and not plugging due to dirt are guaranteed.

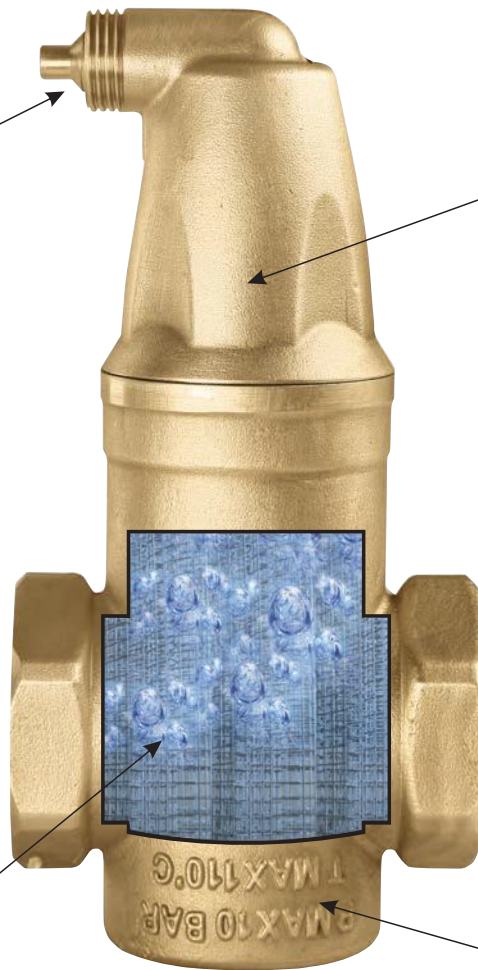

Screwed system connection 3/4"-1"-1 1/4"-1 1/2"-2" for horizontal installation.

MicroSmart design is the most important part of the system. Optimum separation of air and micro bubbles with very low flow resistance.

Long life and strong body.

Installations

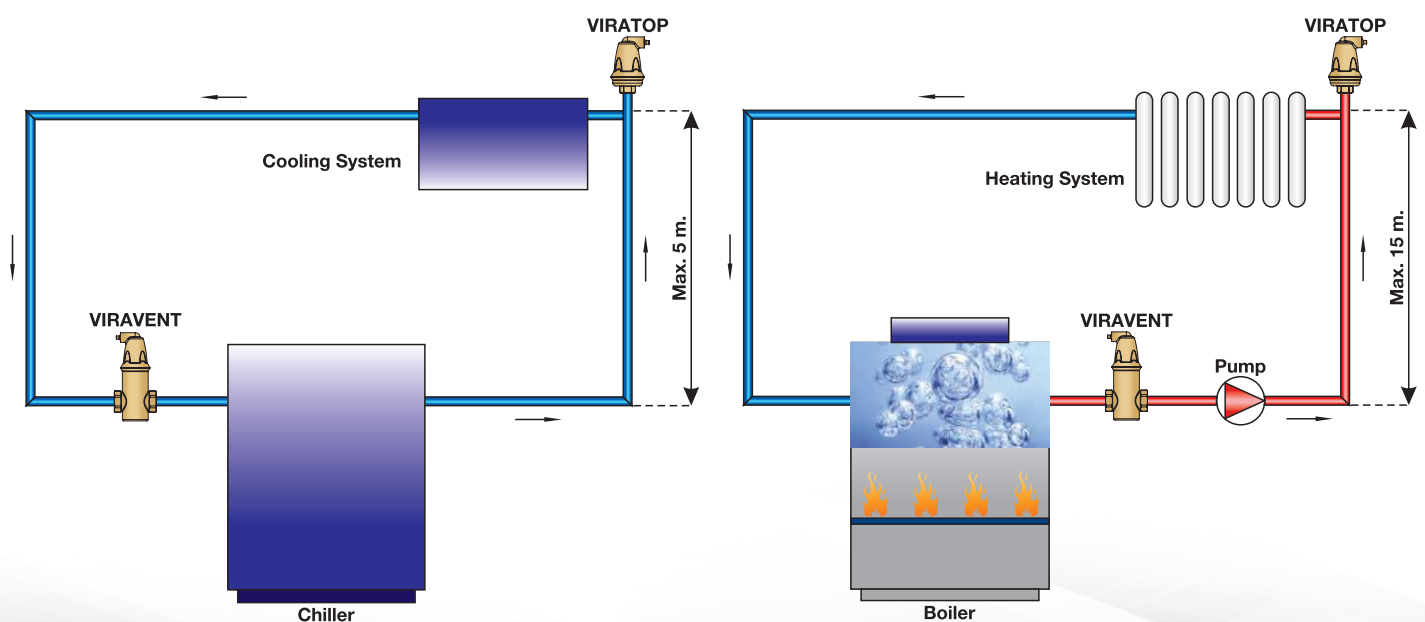

VIRAVENT

AIR SEPERATOR (VERTICAL)

TYPE : SV-D-D

3/4" - 1"



Features	Viravent
Body	: Brass
Connections	: Screwed
Max. Working Temperature	: 110 °C
Max. Working Pressure	: 10 bar
Float	: Polypropylene
Filters	: Stainless Steel

Applications

ViraVent deaerator should always be installed at the hottest point within a system. In the case of a heating system, for example, this is the point where the water exits the boiler. In the case of a cooling system, it is in the return before the chiller unit. When installed in the correct location a ViraVent has the capability to deaerate the entire system as it can make the water absorptive.

Technical Features

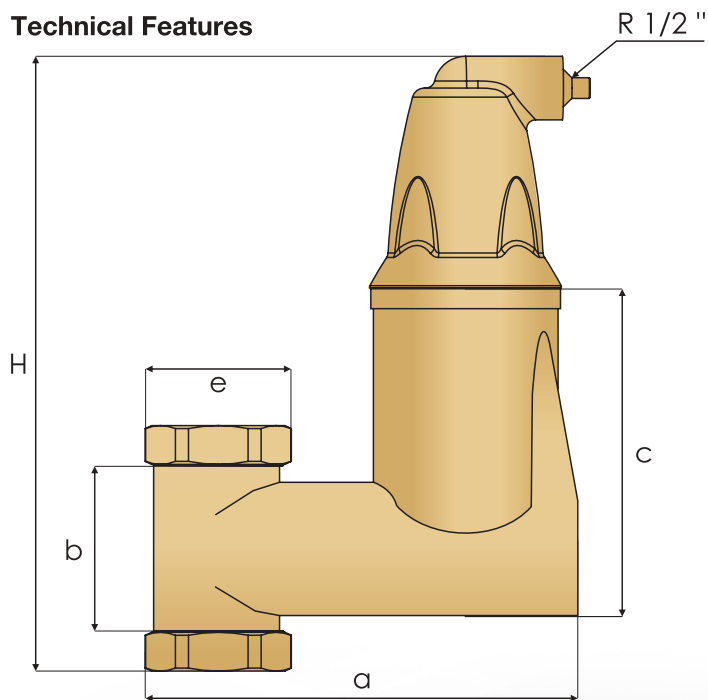

TYPE	d	H	a	b	c	e	Weights
		mm	mm	mm	mm	inch	
SV-D-D	3/4"	210	137	86	115,5	3/4"	1,70
SV-D-D	1"	210	137	86	115,5	1"	1,87

Note : Vira, reserves the right to modify dimensions, material and design without warning.

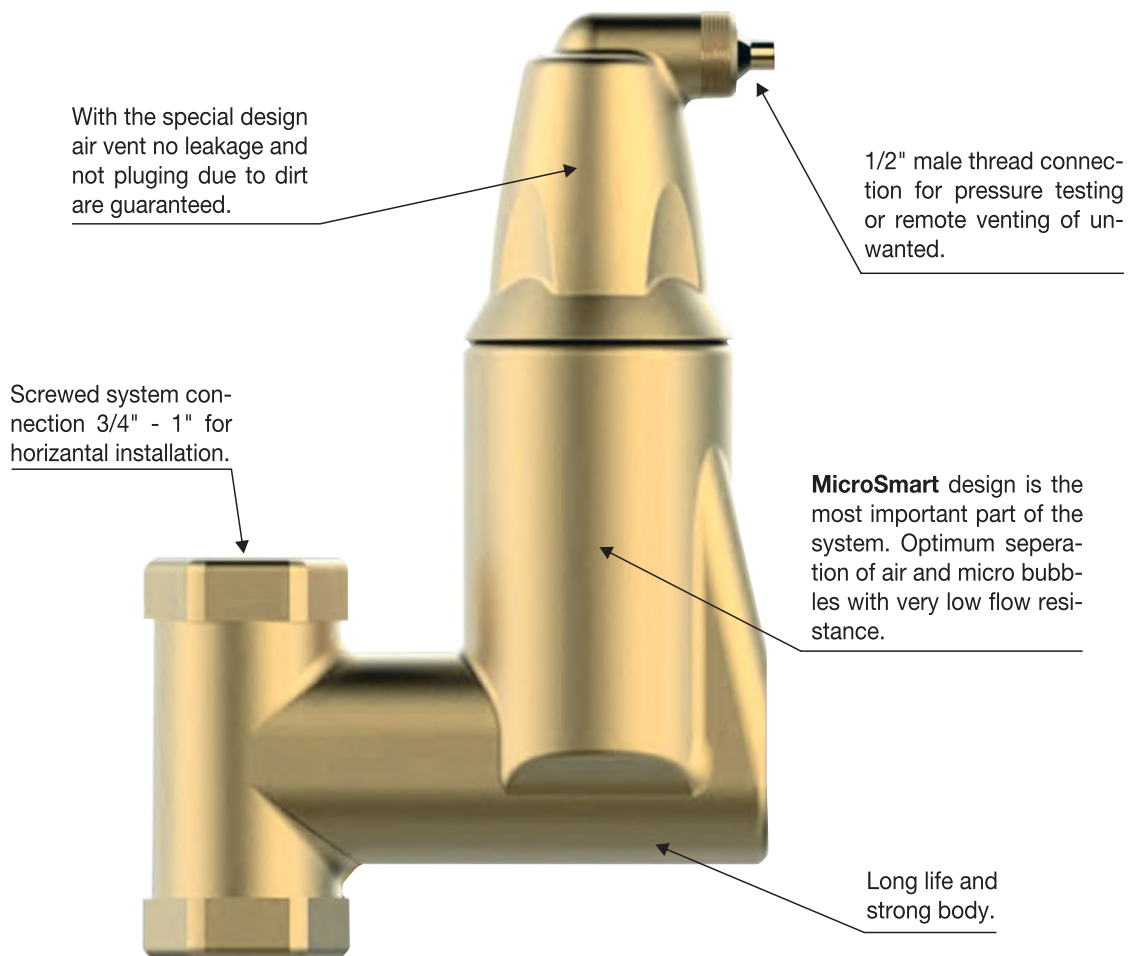

Installations

	<p>H₂O < 50% glycol</p>	
<p>G 3/4" G 1" G 1 1/4" G 1 1/2" G 2"</p>	<p>2</p> <p>1</p>	

VIRAVENT DIRT SEPARATOR

TYPE : SD-D-Y

3/4" - 1" - 1 1/4" - 1 1/2" - 2"



Features	Viraclean SD-D-Y
Body	: Brass
Connections	: Screwed / Horizontal
Max. Working Temperature	: 110 °C
Max. Working Pressure	: 10 bar
Strainer Screen	: Stainless Steel

Applications

VIRACLEAN Dirt Separators, are used in pipelines for the high efficiency removal of impurities from heating and cooling systems in buildings.

VIRACLEAN Dirt Separator should always be installed before equipments (ie. boilers, chillers, control valves, pumps, etc.)

That needs protection from dirt, sludge, etc.

In a heating system this should be in the return.

In a chilled water system the unit must be located in the return close to the chiller.

Technical Features

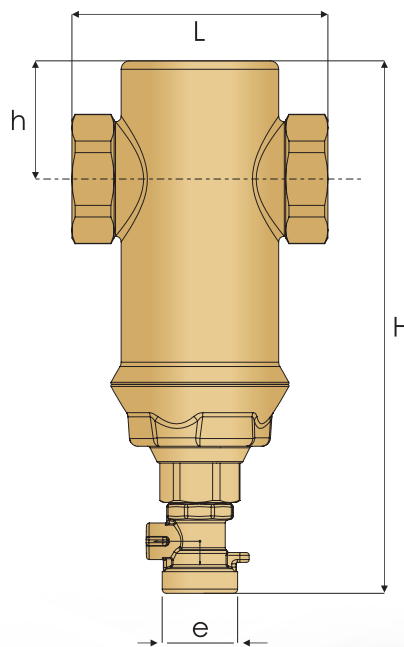

TYPE	DN	H	h	L	R	e	Weights
		mm	mm	mm	mm	inch	kg
SD-D-Y	3/4"	195	25	86	-	1/2"	0,94
SD-D-Y	1"	174	40	85	-	1/2"	0,87
SD-D-Y	1 1/4"	174	41	88	-	1/2"	0,90
SD-D-Y	1 1/2"	198	45	99	-	1/2"	1,15
SD-D-Y	2"	198	46	99	-	1/2"	1,30

Note : Vira, reserves the right to modify dimensions, material and design without warning.

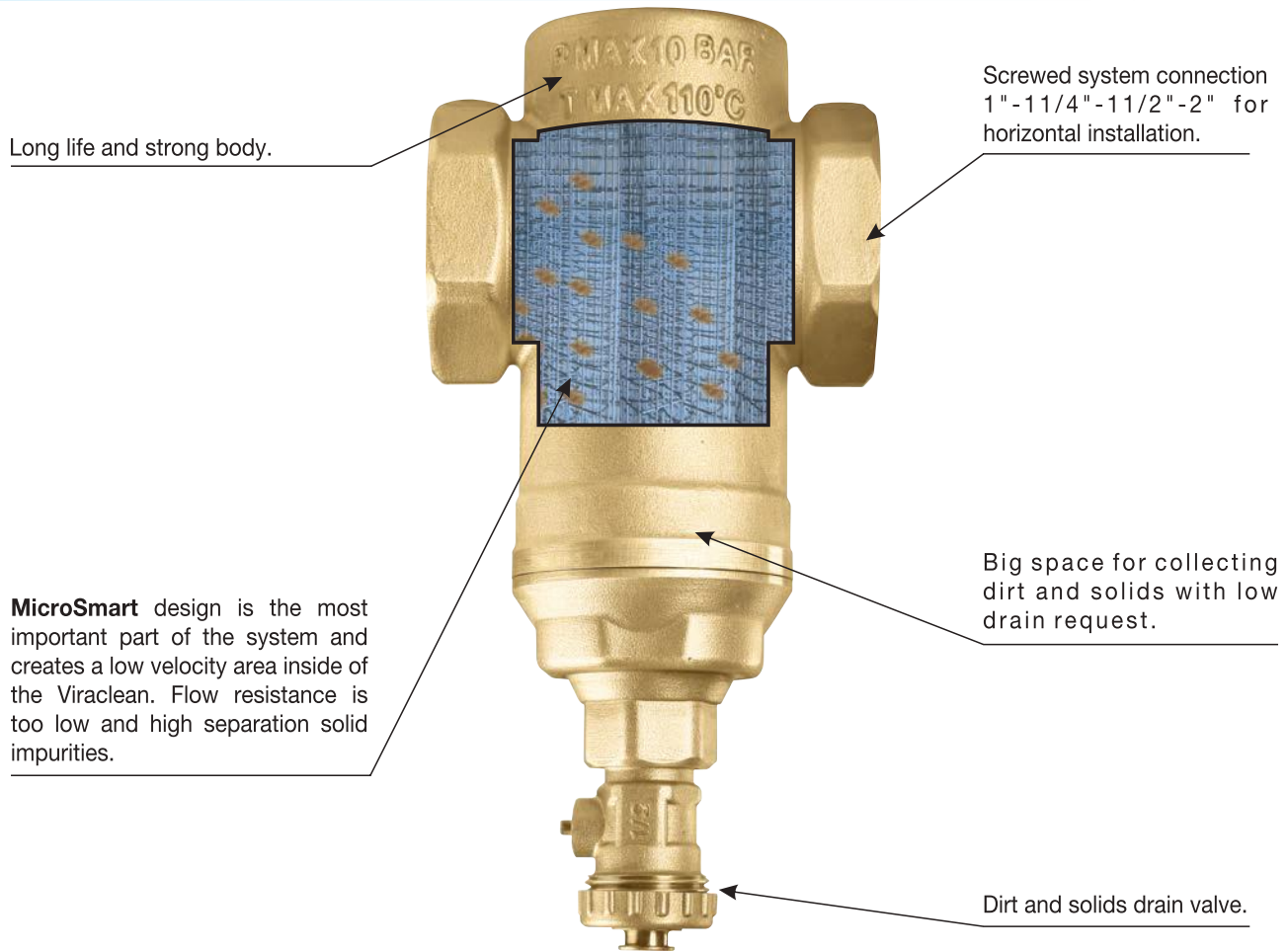

Installations

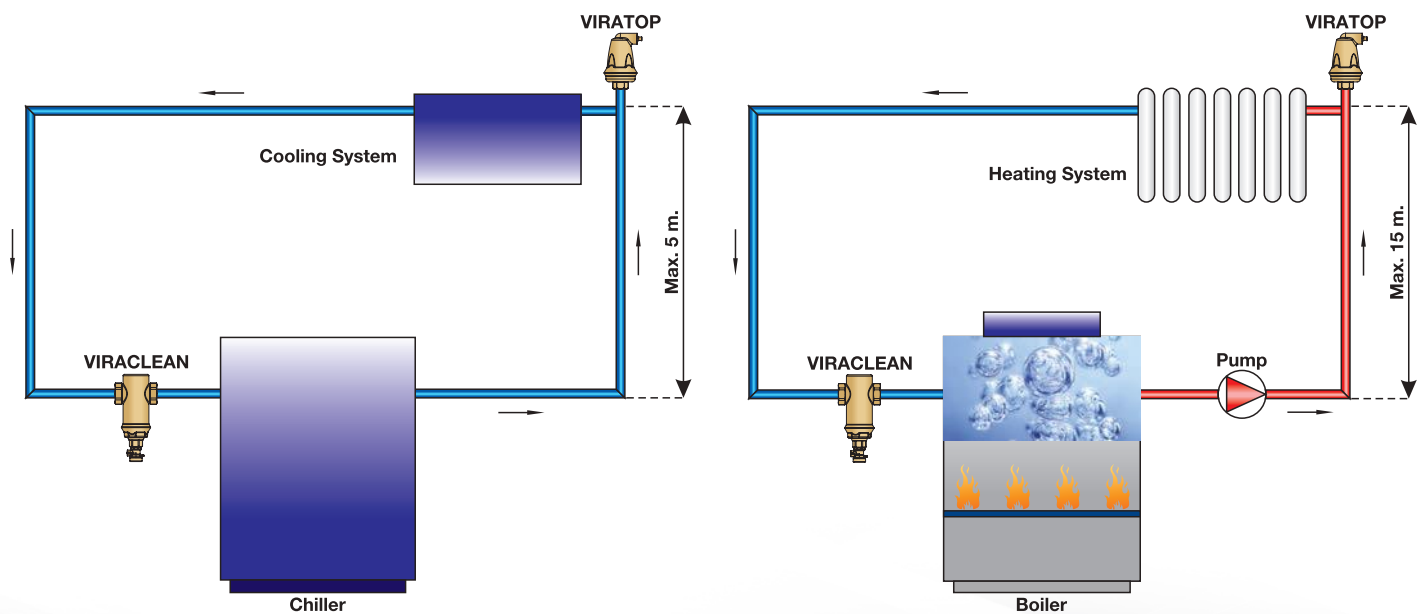

VIRACLEAN

DIRT SEPERATOR (VERTICAL)

TYPE : SD-D-D

3/4" - 1"



Features	Viravent
Body	: Brass
Connections	: Screwed
Max. Working Temperature	: 110 °C
Max. Working Pressure	: 10 bar
Float	: Polypropylene
Filters	: Stainless Steel

Applications

In untreated systems, dirt can accumulate in multiple places throughout the system. Studies and practical experience show that magnetite in particular, leads to greatly reduced energy efficiency and therefore higher energy costs. Ensuring quick and efficient dirt removal is essential. Vira offers an extensive range of ViraClean dirt separators from small brass solutions to heavy duty steel units, especially designed for the removal of dirt.

Technical Features

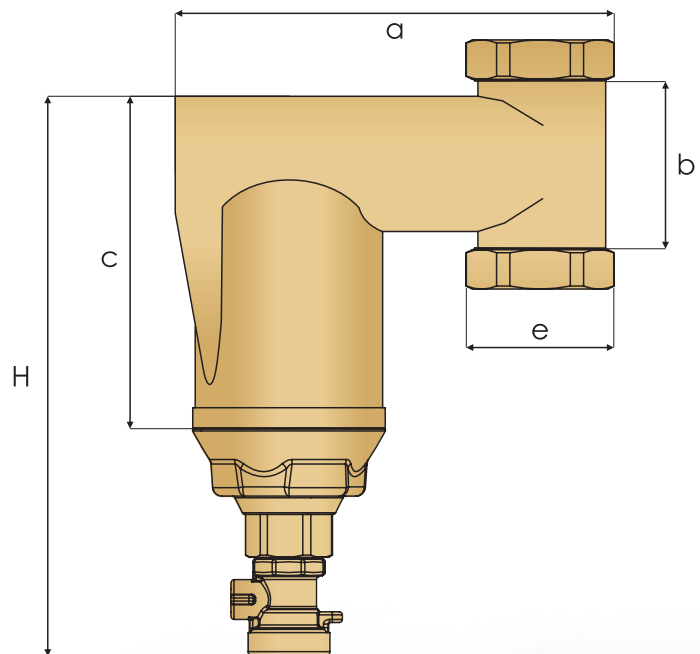

TYPE	d	H	a	b	c	e	Weights
		mm	mm	mm	mm	inch	
SD-D-D	3/4"	214	137	86	115,5	3/4"	1,70
SD-D-D	1"	214	137	86	115,5	1"	1,79

Note : Vira, reserves the right to modify dimensions, material and design without warning.

Long life and strong body.

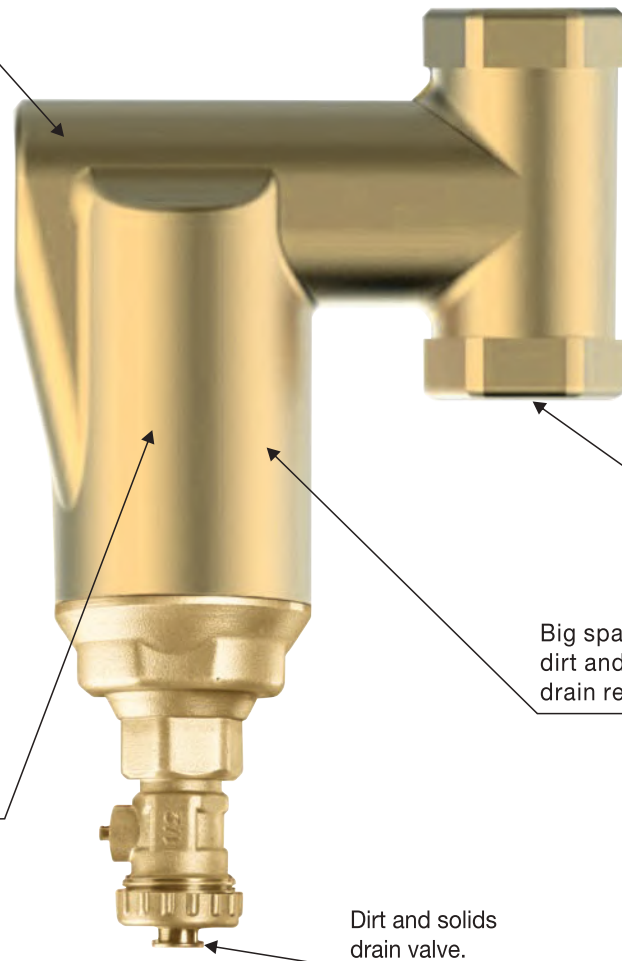

Screwed system connection 3/4"-1" for horizontal installation.

MicroSmart design is the most important part of the system. and creates a low velocity area inside of the Viraclean. Flow resistance is too low and high separation solid impurities.

Big space for collecting dirt and solids with low drain request.

Dirt and solids drain valve.

Installations

<p>0-... bar 0-... °C</p>	<p>< 50% glycol</p>	<p>Ø 22 mm. G 3/4" G 1" G 1 1/4" G 1 1/2" G 2" 0 bar</p>	
<p>Ø 22 mm. G 3/4" G 1" 0 bar</p>	<p>Pmax=1,5x...bar</p>		



New solutions for HVAC... Problem-free



VIRAVENT

Deaerator



VIRACLEAN

Dirt Separator



VIRAPLUS

Deaerator and Dirt Separator



VIRAFIX

Deaerator, Dirt Separator and Hydraulic Balance Tank



VIRABALANCE

Hydraulic Balance Tank

VIRAVENT DEAERATOR

TYPE : SV

DN 50 - 600



Features

Body	: Carbon Steel - ST37
Connections	: Flanged - Welded End - Grooved
Max. Working Temperature	: 110 °C
Max. Working Pressure	: 10 bar
Strainer Screen	: Stainless Steel
Product Range	: SV-F Flanged SV-K Welded End SV-V Grooved
Size	: DN 50 - DN 600

Applications

VIRAVENT Deaerators are used in pipelines for the high efficiency removal of air and micro bubbles from heating and cooling systems in buildings.

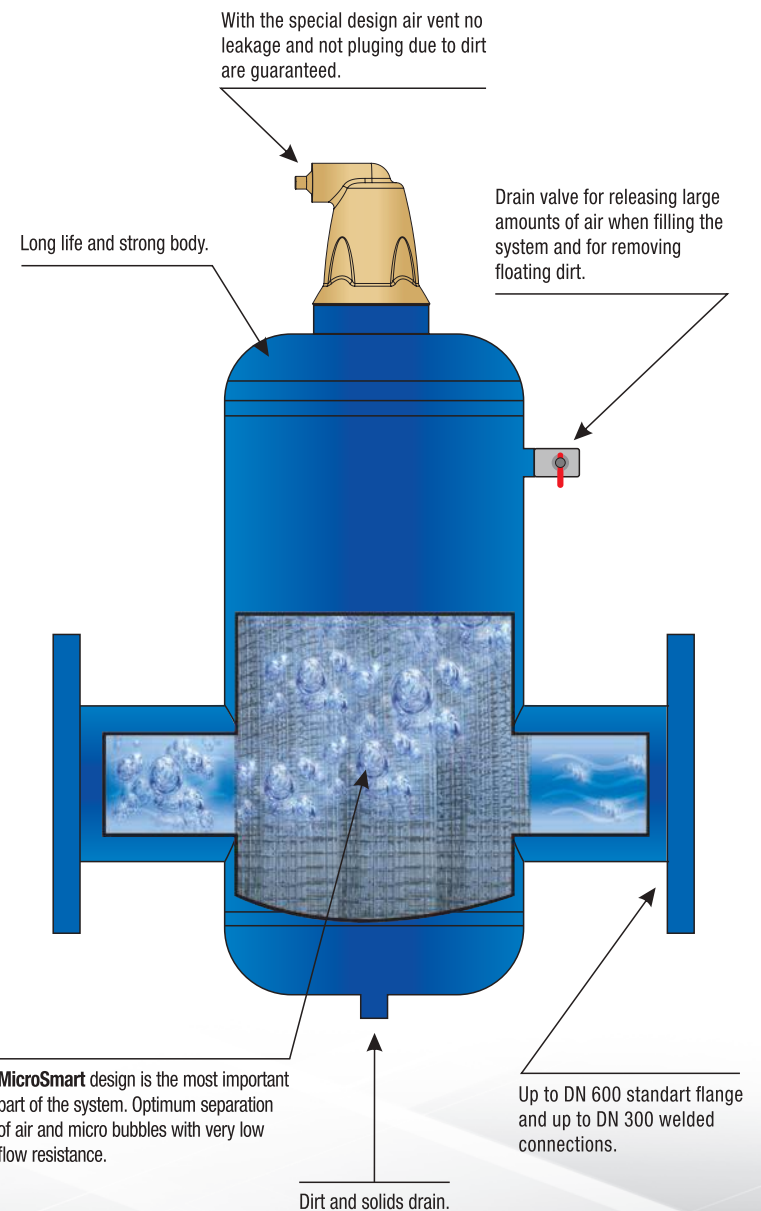

Technical Features

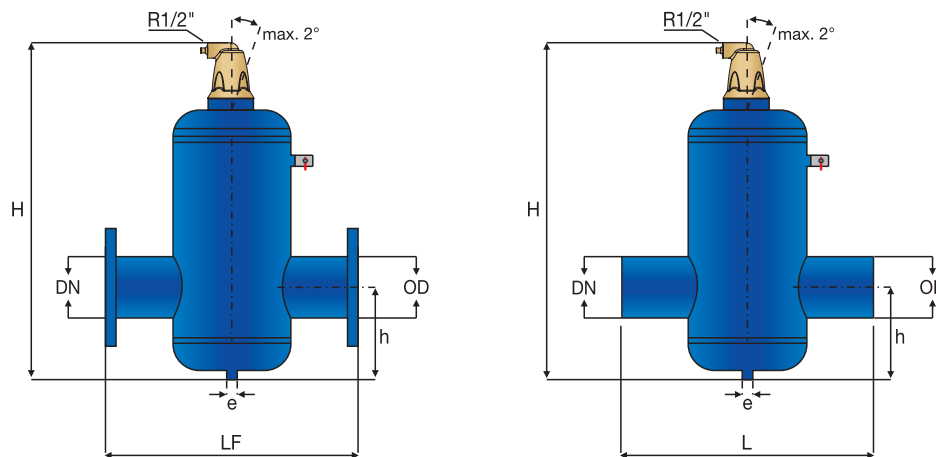

TYPE	DN	OD	H	h	e	LF	L	Flanged Weight	Welded Weight	Flow*	Volume
		mm	mm	mm	inch	mm	mm	kg	kg	m ³ /h	lt
SV	50	60,3	482	138	1"	350	330	15	10	8	6
SV	65	76,1	482	138	1"	350	330	16,5	10	15	6
SV	80	88,9	607	177	1"	470	450	23	15	20	16
SV	100	114,3	607	177	1"	475	455	25	15	30	16
SV	125	139,7	797	267	1"	635	615	47	25	50	50
SV	150	168,3	797	267	1"	635	615	49	37	75	50
SV	200	219,1	996	297	1"	775	745	70	58	125	95
SV	250	273,0	1227	347	2"	890	860	140	120	200	190
SV	300	323,9	1557	385	2"	1005	975	215	190	275	275

* Flow rates when velocity is 1 m/s.

Note : Vira, reserves the right to modify dimensions, material and design without warning.

Installations

VIRAVENT unit must be installed at the hottest part of the system for optimum performance. The static head must not exceed 15m for heating system and 5m for cooling system.

The efficiency of the unit will be reduced if;

- The static head is exceeded.
- The maximum flow velocity of 3m/s is exceeded.

In heating systems the deaerator should be in the flow, preferably at the highest temperature (next to the heat source) and low pressure if possible. Viravent, Deaerator should be installed after the boiler and on the pump suction side, as these are the points where the formation of micro bubbles is greatest. In chilled water systems the unit must be located in the return close to the chiller.

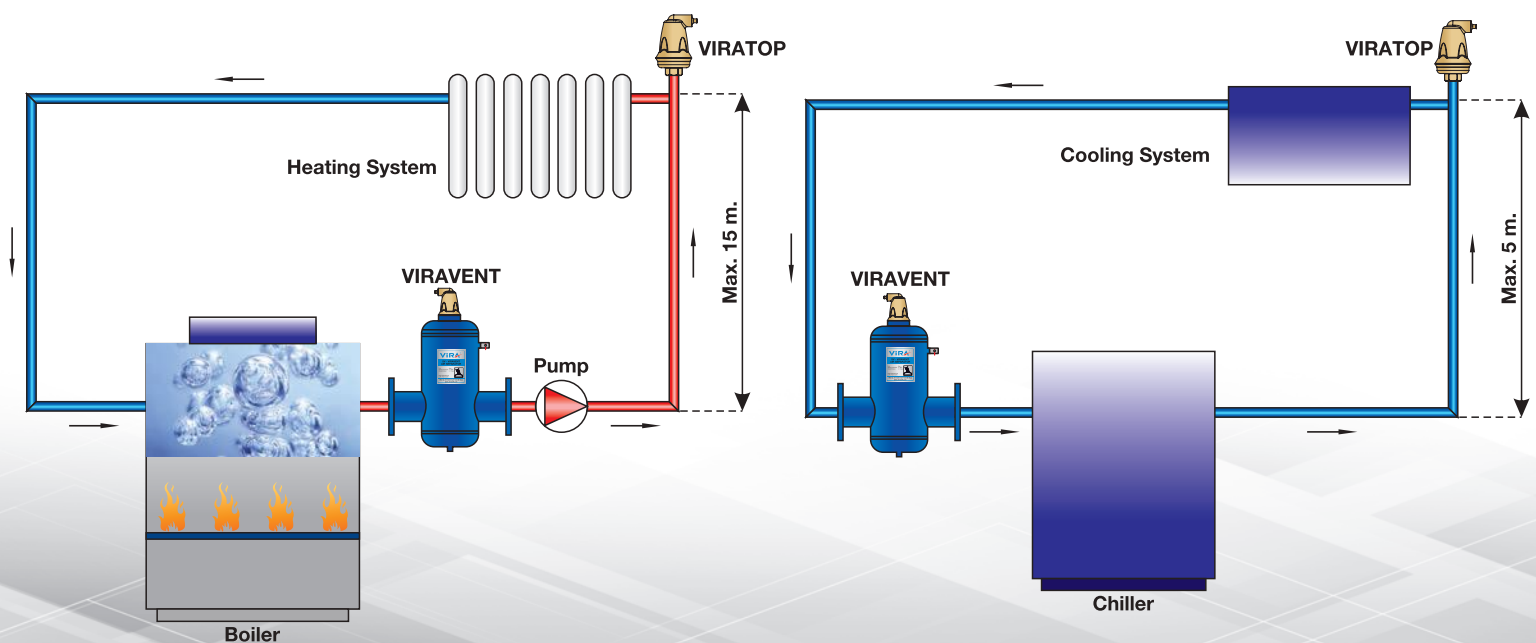

VIRACLEAN DIRT SEPARATOR

TYPE : SD

DN 50 - 600



Features

Body	: Carbon Steel - ST37
Connections	: Flanged - Welded End - Grooved
Max. Working Temperature	: 110 °C
Max. Working Pressure	: 10 bar
Strainer Screen	: Stainless Steel
Product Range	: SD-F Flanged SD-K Welded End SD-V Grooved SD-F-T Flanged-Removable SD-K-T Welded End-Removable SD-V-T Grooved Removable
Size	: DN 50 - DN 600

Applications

VIRACLEAN Dirt Separators are used in pipelines for the high efficiency removal of impurities from heating and cooling systems in buildings.

MicroSmart design is the most important part of the system and creates a low velocity area inside of the VIRACLEAN. Flow resistance is too low and high separation solid impurities.

Up to DN 600 standart flange and up to DN 300 welded connections.

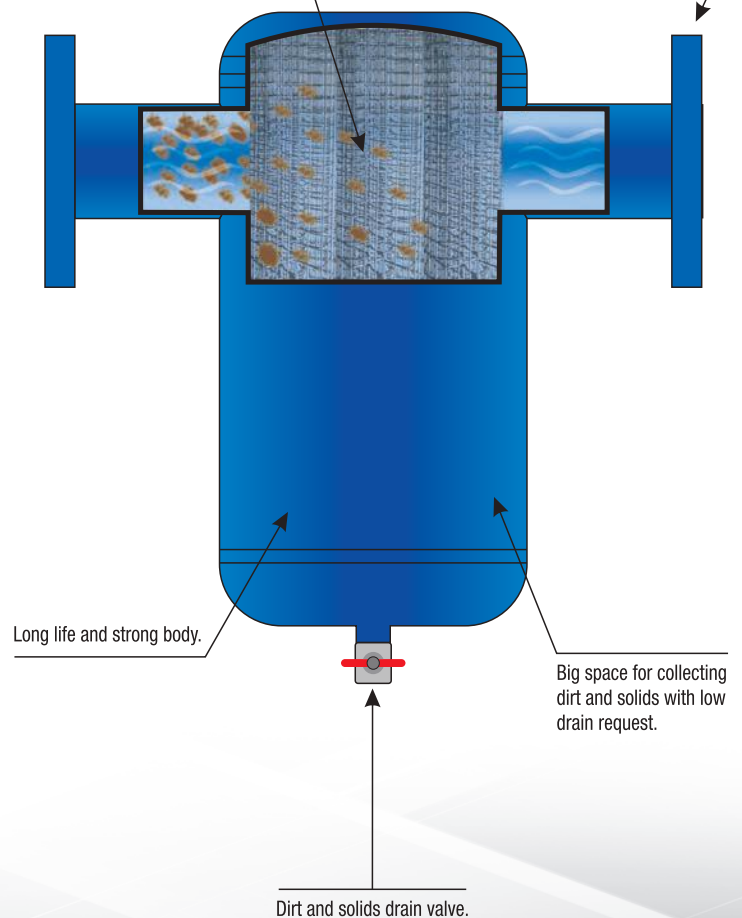

Technical Features

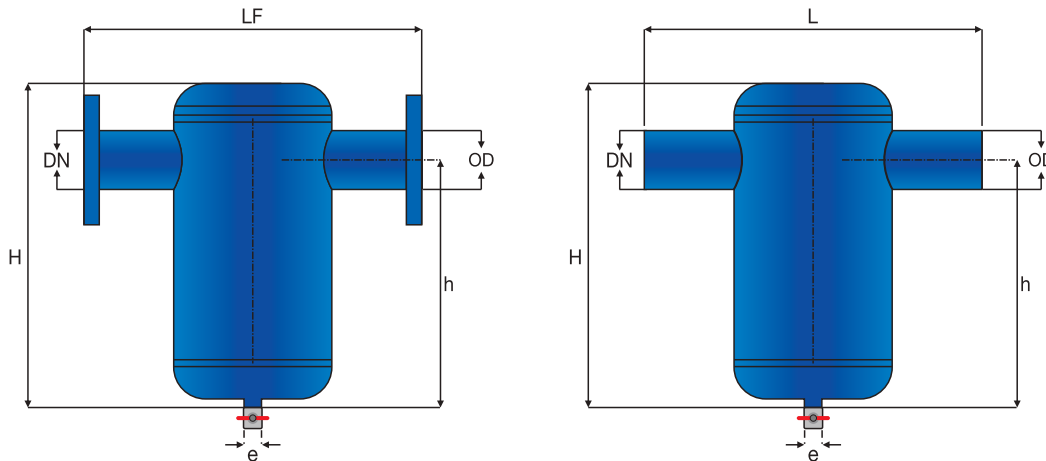

TYPE	DN	OD	H	h	e	LF	L	Flanged Weight	Welded Weight	Flow*	Volume
		mm	mm	mm	inch	mm	mm	kg	kg	m ³ /h	lt
SD	50	60,3	385	267	1"	350	330	15	10	8	6
SD	65	76,1	385	265	1"	350	330	17	10	15	6
SD	80	88,9	510	390	1"	470	450	23	14	20	16
SD	100	114,3	510	353	1"	475	455	26	17	30	16
SD	125	139,7	701	454	1"	635	615	44	34	50	50
SD	150	168,3	701	454	1"	635	615	48	37	75	50
SD	200	219,1	900	623	1"	775	745	68	56	125	95
SD	250	273,0	1130	840	2"	890	860	136	116	200	190
SD	300	323,9	1460	1095	2"	1005	975	205	180	275	275

* Flow rates when velocity is 1 m/s.

Note : Vira, reserves the right to modify dimensions, material and design without warning.

Installations

VIRACLEAN Dirt Separator should always be installed before equipment (ie. boilers, chillers, controll valves, pumps, etc.) That needs protection from dirt, sludge, etc.

In heating systems this should be in the return.

In chilled water systems the unit must be located in the return close to the chiller.

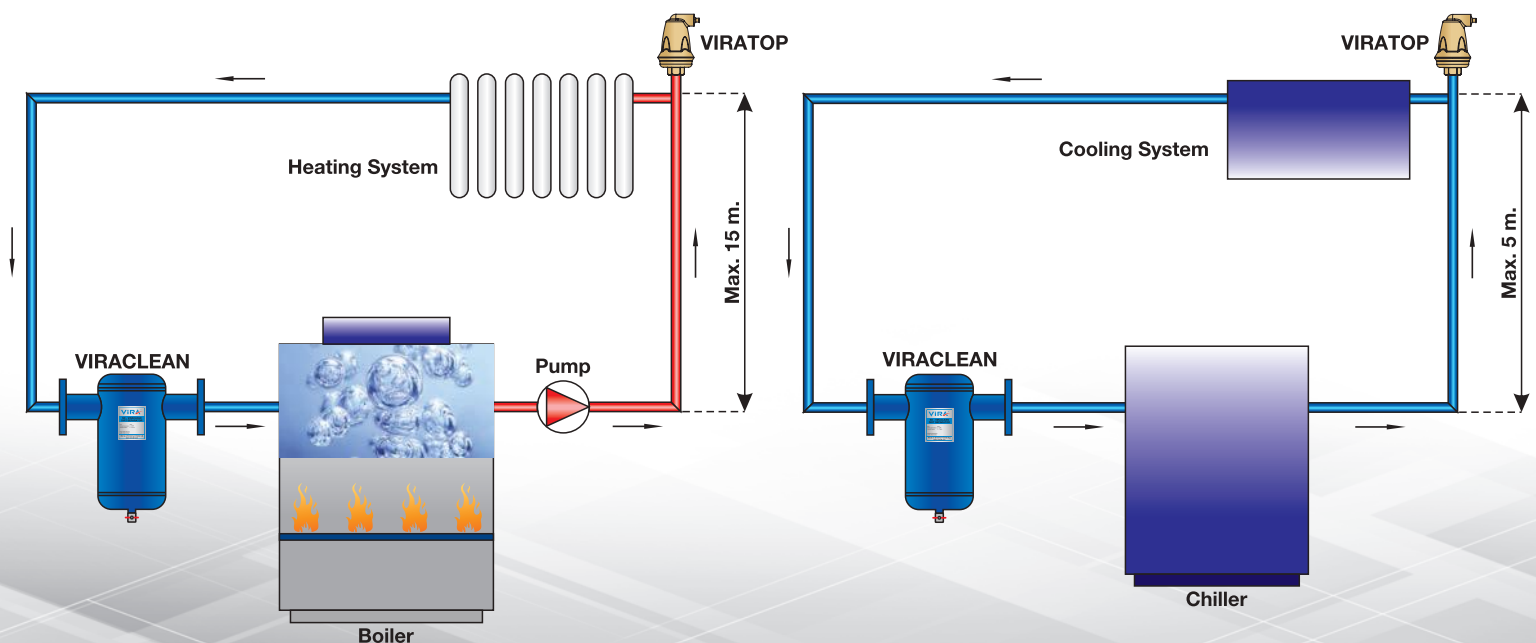

VIRAPLUS

DEAERATOR AND DIRT SEPARATOR

TYPE : SC

DN 50 - 600



Features

Body	: Carbon Steel - ST37
Connections	: Flanged - Welded End - Grooved
Max. Working Temperature	: 110 °C
Max. Working Pressure	: 10 bar
Strainer Screen	: Stainless Steel
Product Range	: SC-F Flanged
	SC-K Welded End
	SC-V Grooved
	SC-F-T Flanged-Removable
	SC-K-T Welded End-Removable
	SC-V-T Grooved Removable
Size	: DN 50 - DN 600

Applications

VIRAPLUS Deaerator and Dirt Separators are used in pipelines for the high efficiency removal of both dirt and air, micro bubbles from heating and cooling systems in buildings.

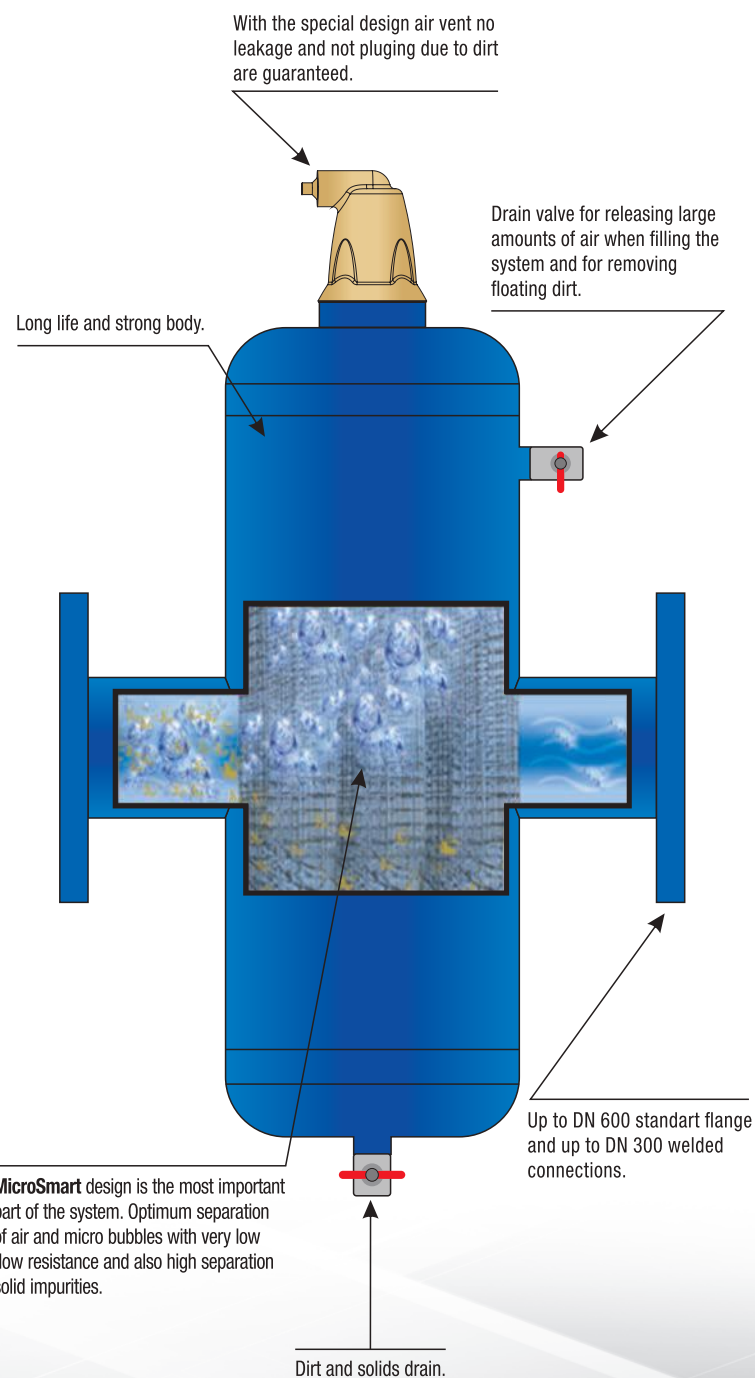

Technical Features

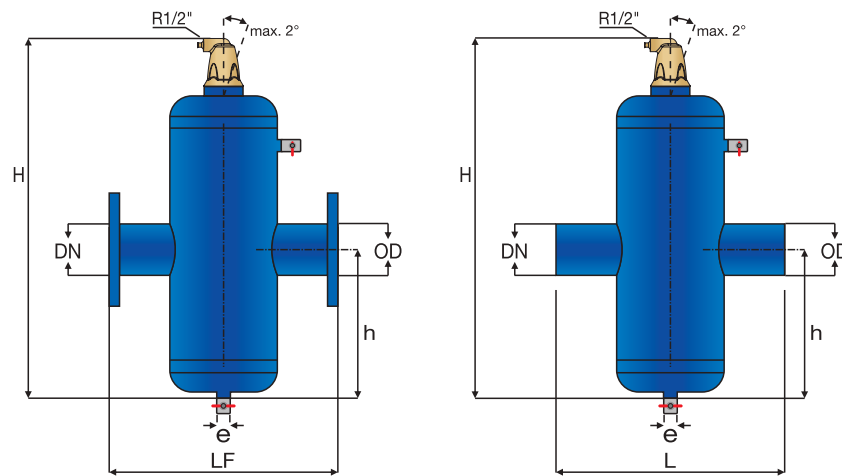

TYPE	DN	OD	H	h	e	LF	L	Flanged Weight	Welded Weight	Flow*	Volume
		mm	mm	mm	inch	mm	mm				
SC	50	60,3	632	265	1"	350	330	17	13	8	10
SC	65	76,1	632	265	1"	350	330	21	13	15	10
SC	80	88,9	791	345	1"	470	450	27	22	20	24
SC	100	114,3	791	345	1"	475	455	30	23	30	24
SC	125	139,7	1064	480	1"	635	615	53	45	50	70
SC	150	168,3	1064	480	1"	635	615	81	67	75	70
SC	200	219,1	1307	615	1"	775	745	101	85	125	140
SC	250	273,0	1568	805	2"	890	860	150	130	200	265
SC	300	323,9	1892	1110	2"	1005	975	227	202	275	465

* Flow rates when velocity is 1 m/s.

Note: Vira, reserves the right to modify dimensions, material and design without warning.

Installations

VIRAPLUS is a combination of deaerator and dirt separator which removes circulating air and micro bubbles also dirt effectively. In heating systems the Viraplus should be in the flow and installed after the boiler

In chilled water systems the unit must be located in the return close to the chiller.

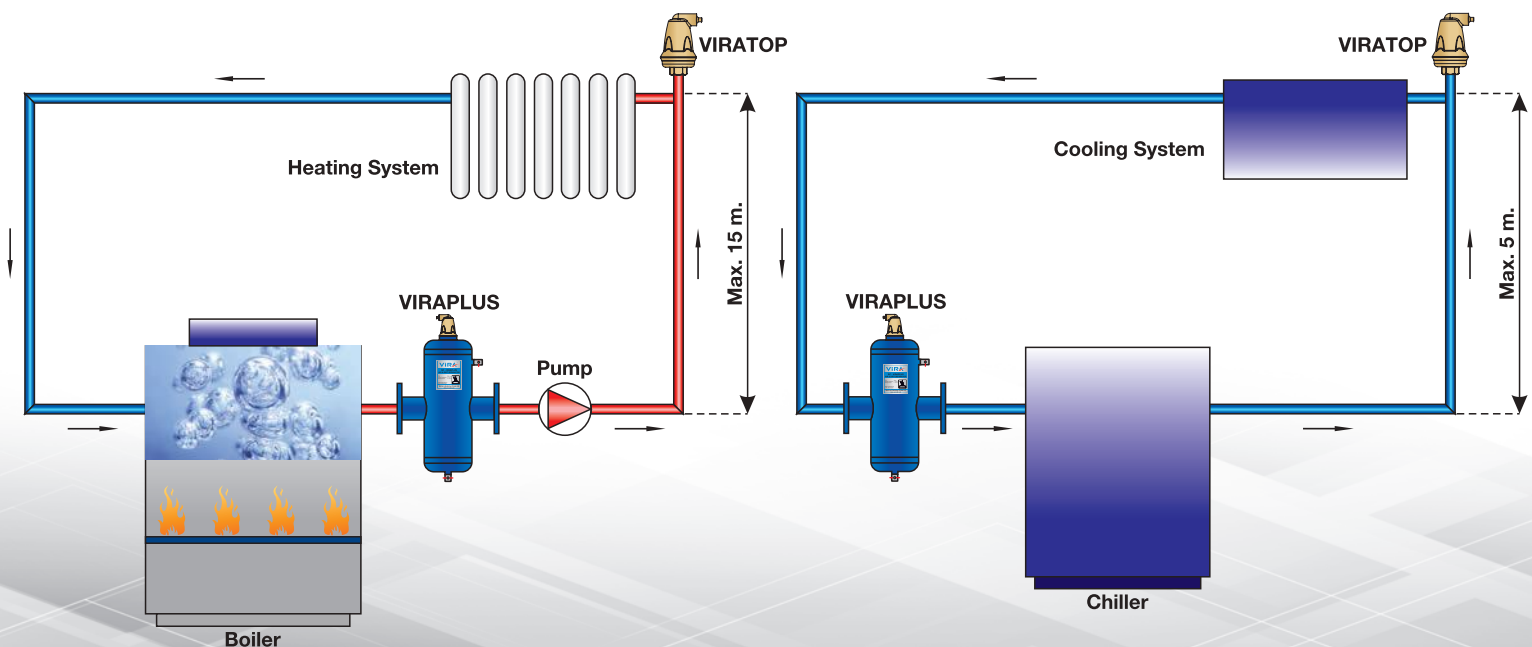

VIRAFIX

DEAERATOR, DIRT AND HYDRAULIC SEPARATOR

TYPE : SCX

DN 50 - 600



Features

Body	: Carbon Steel - ST37
Connections	: Flanged - Welded End - Grooved
Max. Working Temperature	: 110 °C
Max. Working Pressure	: 10 bar
Strainer Screen	: Stainless Steel
Product Range	: SCX-F Flanged SCX-K Welded End SCX-V Grooved
Size	: DN 50 - DN 600

Applications

VIRAFIX Deaerators and Dirt Separators are used in pipelines for the high efficiency removal of both dirt and air, micro bubbles from heating and cooling systems in buildings.

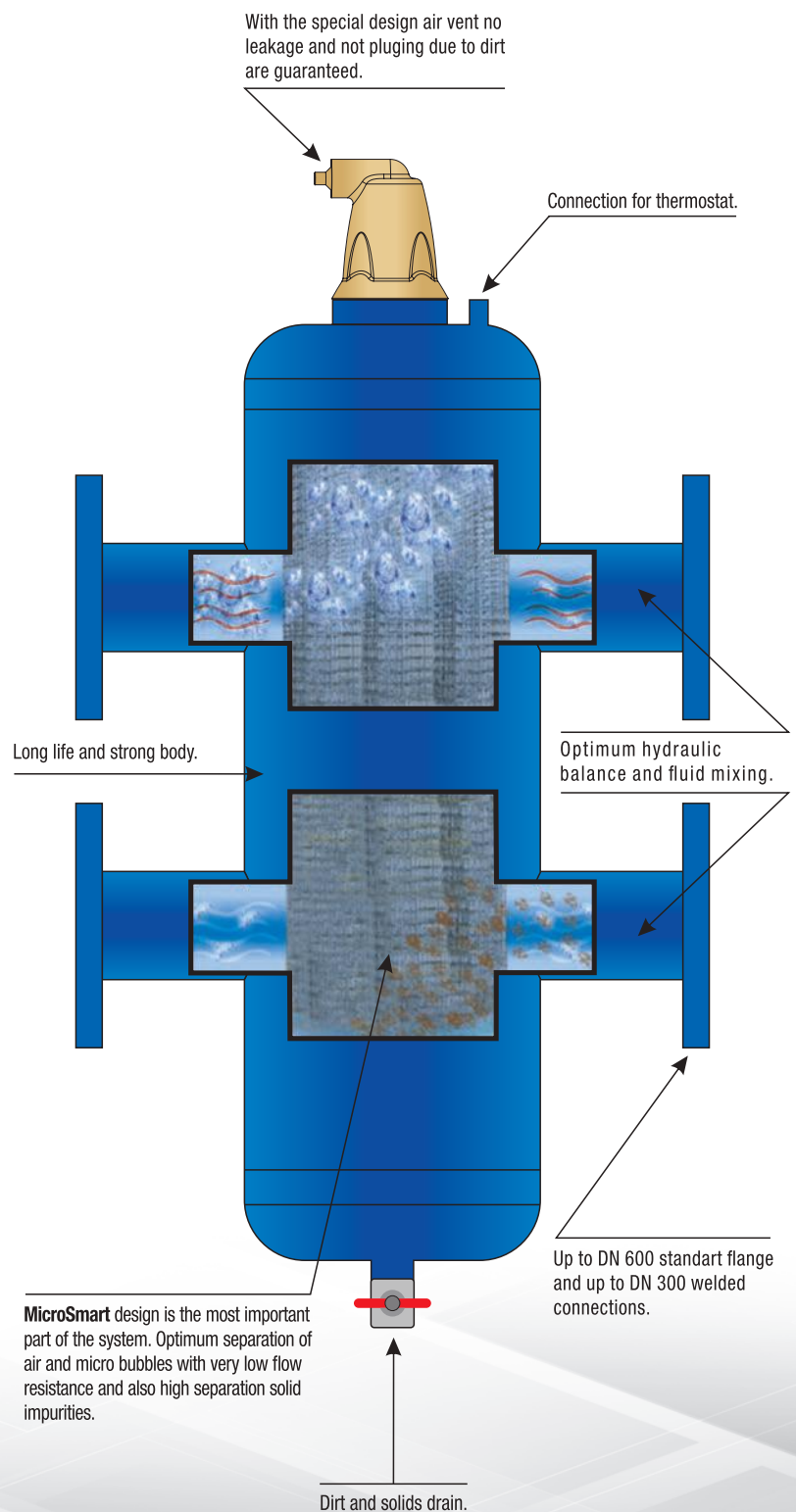

Technical Features

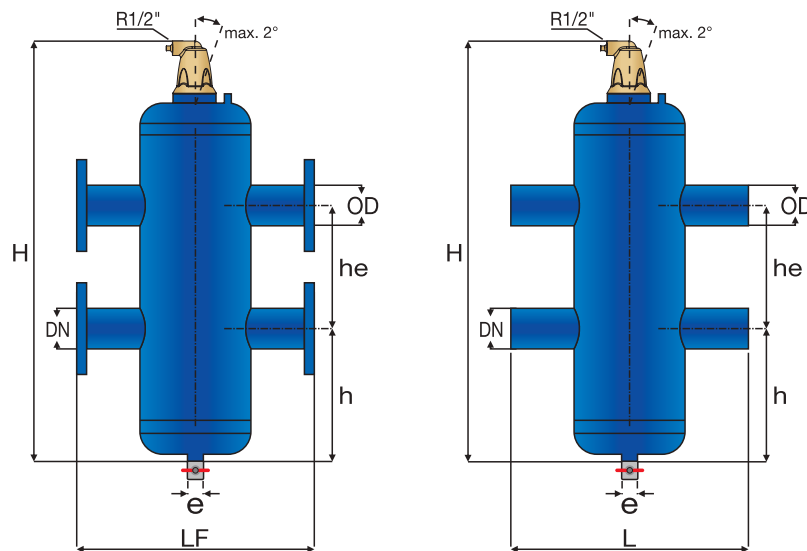

TYPE	DN	OD	H	h	he	e	LF	L	Capacity		Flow*
									($\Delta T=15^{\circ}\text{C}$)	($\Delta T=6^{\circ}\text{C}$)	
		mm	mm	mm	mm	inch	mm	mm	kW	kW	m ³ /h
SCX	050/150	60,3	812	248	240	1"	350	330	218	87	12,5
SCX	065/150	76,1	927	273	305	1"	350	330	349	140	20
SCX	080/200	88,9	982	273	360	1"	470	450	471	188	27
SCX	100/200	114,3	1232	348	462	1"	475	455	820	328	47
SCX	125/300	139,7	1532	448	560	1"	635	615	1256	502	72
SCX	150/300	168,3	1832	543	670	1"	635	615	1884	753	108
SCX	200/400	219,1	2336	695	870	1"	775	745	3143	1256	180
SCX	250/500	273,0	2876	850	1100	2"	890	860	5023	2009	288
SCX	300/600	323,9	3392	1010	1295	2"	1005	975	7064	2826	405

* Flow rates when velocity is 1,5 m/s.

Note : Vira, reserves the right to modify dimensions, material and design without warning.

Installations

Installation of a hydraulic separator in a heating system provides proper mixing, when flow in the boiler circuit is different from flow in the distribution circuit. Also VIRAFIX is a combination of deaerator, dirt separator and hydraulic separator which removes circulating air and micro bubbles also dirt effectively.

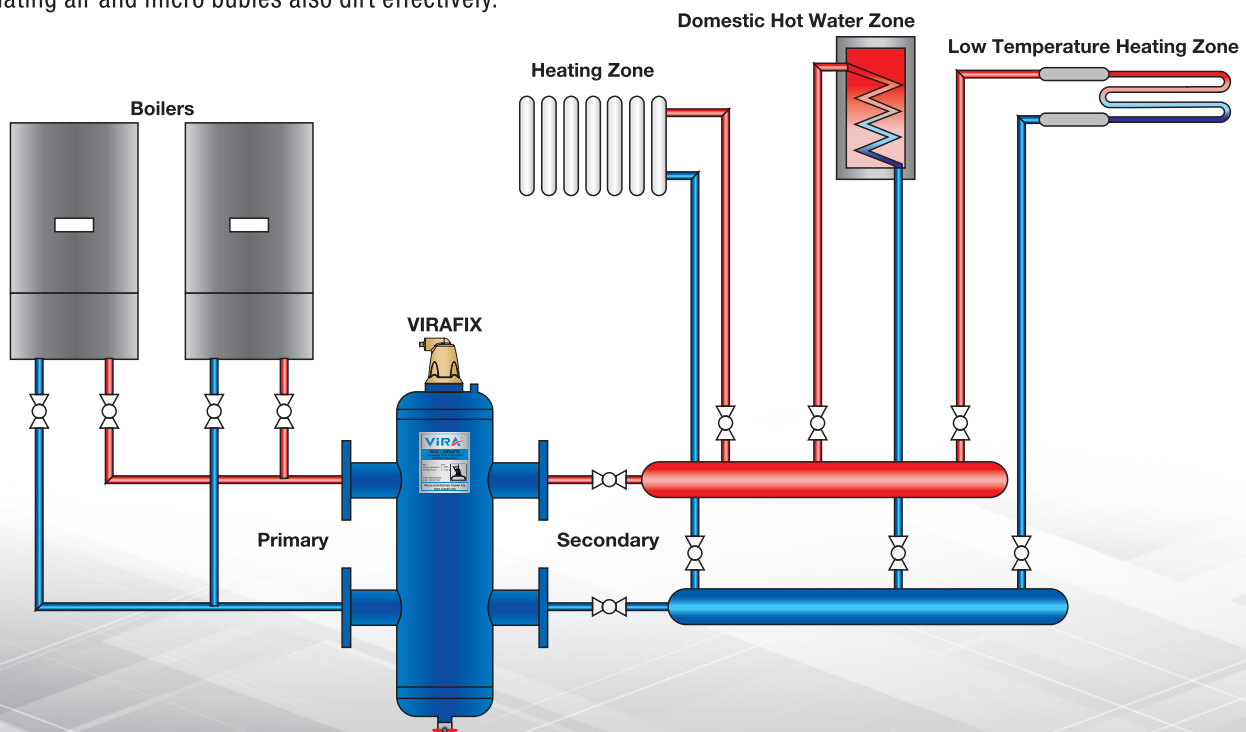

VIRABALANCE

HYDRAULIC BALANCE TANK

TYPE : SB

DN 32 - 600



Features

Body	: Carbon Steel - ST37
Connections	: Flanged - Welded End - Screwed
Max. Working Temperature	: 110 °C
Max. Working Pressure	: 10 bar
Strainer Screen	: Stainless Steel
Product Range	: SB-F Flanged SB-K Welded End SB-D Screwed
Size	: DN 50 - DN 600

Applications

VIRABALANCE Hydraulic Balance Tank are compact economical units that allow fast and efficient installation of primary/secondary piping for many different boilers systems. When more then one boiler is used at primary loop, more then one pump will run and create abnormal variations in circuit flow rates and pressures. A Hydraulic Balance Tank installs between the primary and secondary loops and eliminates the need for an additional pump to circulate fluid through the primary loop. Thereby boilers and the heating circuits can have the proper flow rate independently.

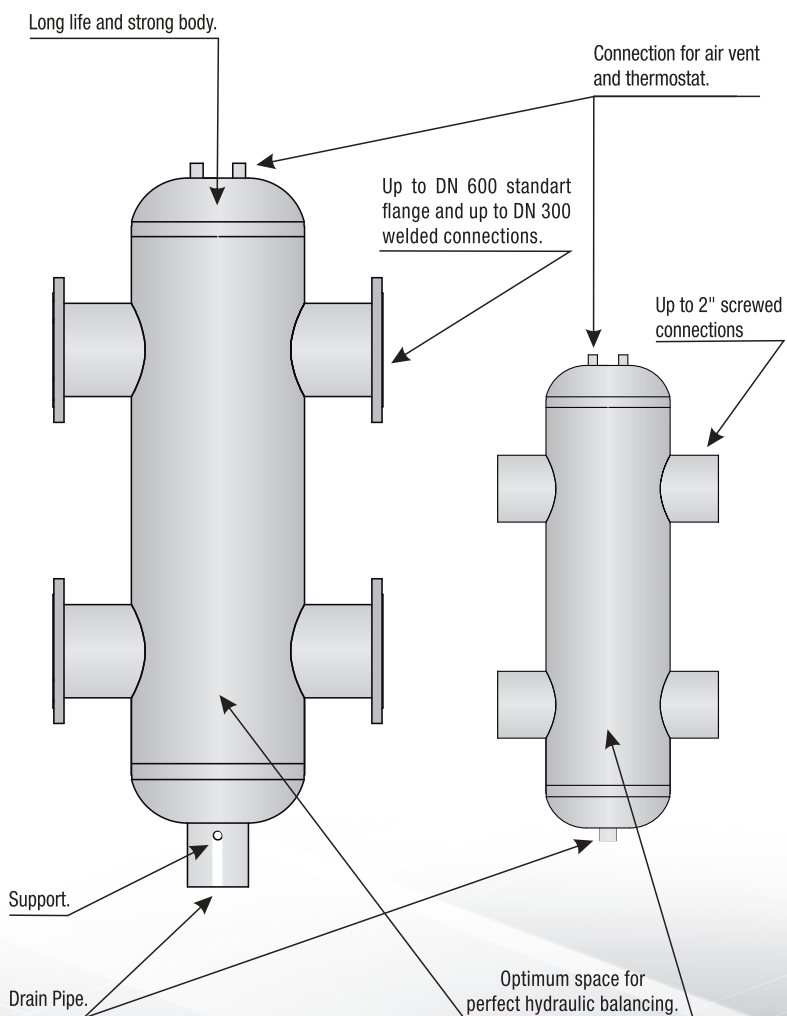

Technical Features

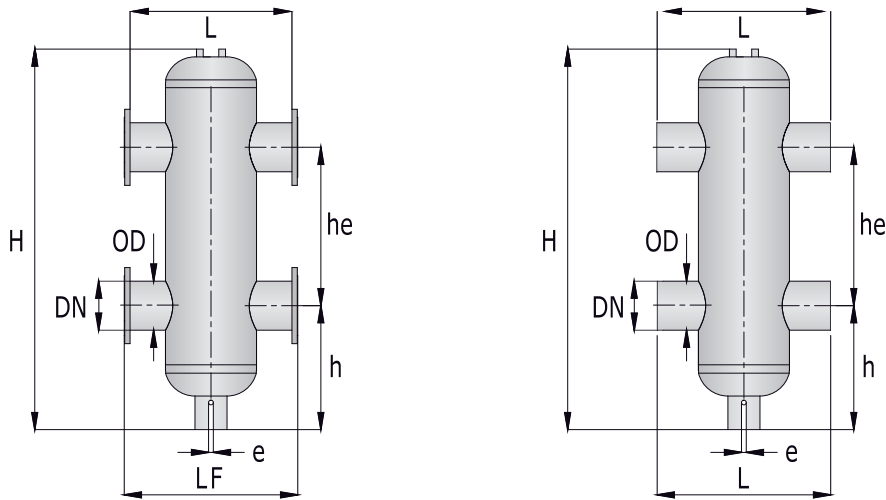

TYPE	DN	OD	H	h	he	e	LF	L	Capacity		Flow*
									($\Delta T=15^{\circ}\text{C}$)	($\Delta T=6^{\circ}\text{C}$)	
		mm	mm	mm	mm	inch	mm	mm	kW	kW	m ³ /h
SB	032/065	42,4	389	80	228	1/2"	217	190	30	12	1,7
SB	040/080	48,3	453	93	267	3/4"	237	210	45	18	2,6
SB	050/100	60,3	562	109	343	3/4"	286	266	70	28	4,0
SB	065/125	76,1	685	133	419	3/4"	312	292	100	40	5,7
SB	065/150	76,1	862	178	505	1"	350	330	140	56	8,0
SB	080/200	88,9	1242	357	657	1"	470	450	210	84	12
SB	100/200	114,3	1242	357	657	1"	475	455	350	140	20
SB	125/250	139,7	1535	423	819	1 1/4"	584	564	550	220	32
SB	150/300	168,3	1793	476	972	1 1/4"	635	615	900	360	52
SB	150/350	168,3	2170	617	1067	1 1/2"	667	647	1300	520	75
SB	200/400	219,1	2197	554	1219	1 1/2"	775	745	1750	700	100

* Flow rates when velocity is 1 m/s.

Note : Vira, reserves the right to modify dimensions, material and design without warning.

Installations

Installation of a hydraulic balance tank in a heating system provides proper mixing, when flow in the boiler circuit from flow in the distribution circuit.

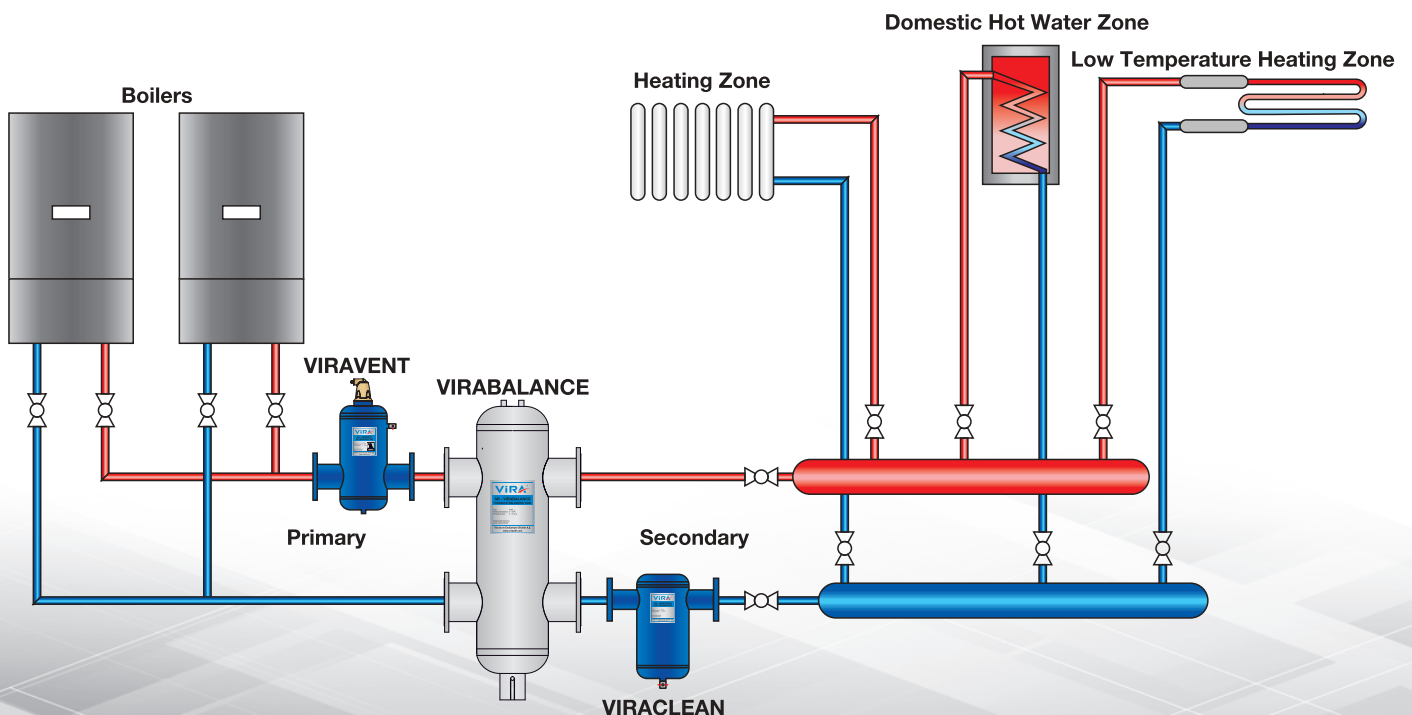

VIRABALANCE

HYDRAULIC BALANCE TANK

How Works Hydraulic Balance Tank

Three operating situation can occur if a hydraulic balance tank is installed in a heating system.

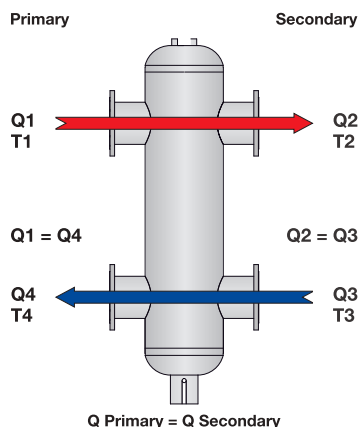

• Primary Flow Equal to Secondary Flow

When the system flow is equal to the secondary flow, all the primary water is directed to the zones and all the return water goes back to the heat source. The temperature of the zone water is the same as that supplied by the heat source and the return water temperature to the heat source equals the return water temperature from the zones. In this situation, supply and demand are equal. $Q_{\text{primary}} = Q_{\text{secondary}}$

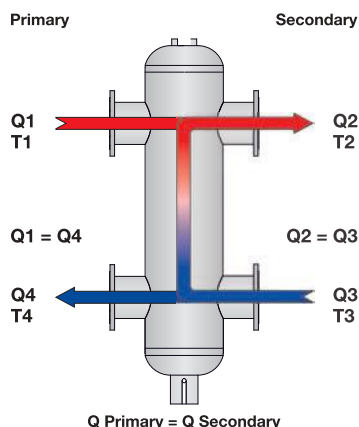

• The Primary Flow Rate Less Than Secondary Flow Rate

When the primary flow rate is less than the secondary flow rate, the supply water temperature to the zones will be a mix of the supply water from the heat source and the return water from the zones. The return water to the heat source will always be the same as the return water from the zones. In this situation, the power of the boiler will be increased. $Q_{\text{primary}} < Q_{\text{secondary}}$

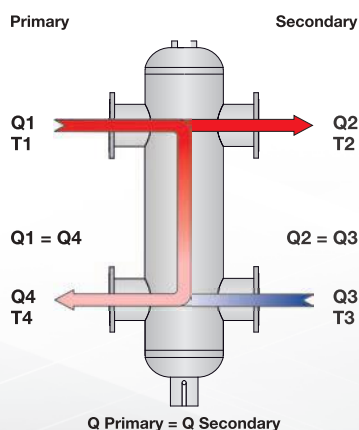

• The Primary Flow Rate Greater Than Secondary Flow Rate

When the primary flow rate is greater than the secondary flow rate, the supply temperature from the heat source will be the temperature of the water to the zone. The return water to the heat source will be a mix of the heat source water and zone return water. In this situation, the power of the boiler will be modulated downwards. $Q_{\text{primary}} > Q_{\text{secondary}}$



VIRACLEAN

Magnetic
Dirt Separator



VIRAPLUS

Magnetic
Deaerator and Dirt Separator



VIRAFIX

Magnetic
Deaerator, Dirt Separator and Hydraulic Balance Tank



VIRADOSING

Chemical Design Pots

MAGNETIC VIRACLEAN DIRT SEPARATOR

TYPE : SD-M

DN 50 - 600



Features

Body	: Carbon Steel - ST37
Connections	: Flanged - Welded End - Grooved
Max. Working Temperature	: 110 °C
Max. Working Pressure	: 10 bar
Strainer Screen	: Stainless Steel
Product Range	: SD-F-M Flanged SD-K-M Welded End SD-V-M Grooved
Size	: DN 50 - DN 600

Applications

ViraClean dirt separators are installed inline and continuously remove even the smallest dirt particles from the system fluid. Magnetic ViraClean is equipped with a powerful removable magnet that directs its powerful force inwards which ensures extremely effective separation. The new solution brings all the advantages of the highly successful to bigger connection sizes. For even larger applications, we recommend our magnetic ViraClean.

MicroSmart design is the most important part of the system and creates a low velocity area inside of the SMARTTRAP. Flow resistance is too low and high separation solid impurities.

Up to DN 600 standart flange and up to DN 300 welded connections.

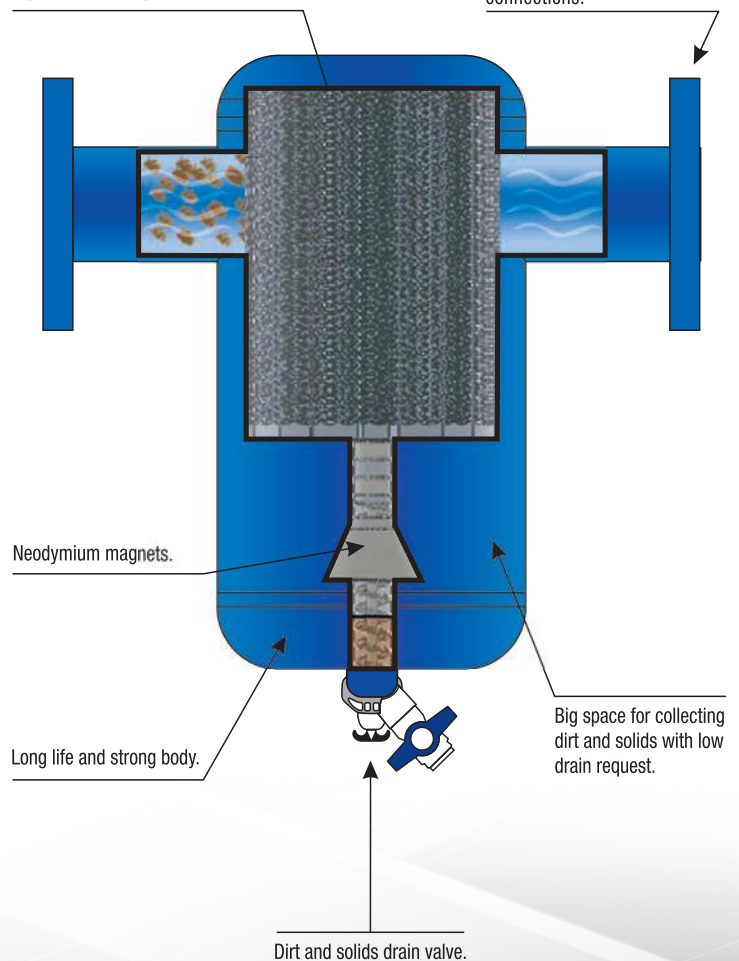

Technical Features

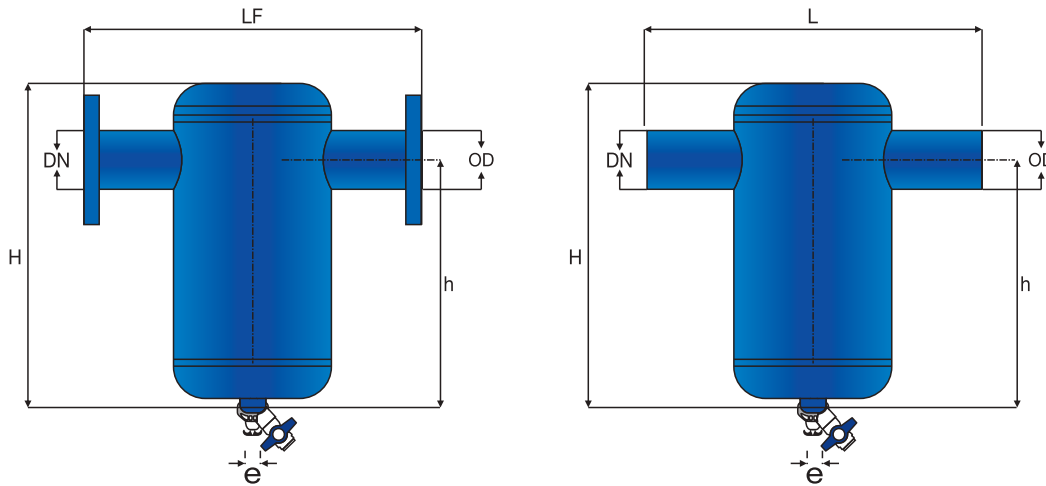

TYPE	DN	OD	H	h	e	LF	L	Flanged Weight	Welded Weight	Flow*	Volume
		mm	mm	mm	mm	inch	mm	mm	kg	kg	m ³ /h
SD-M	50	60,3	394	267	3/4"	350	330	16	11	8	6
SD-M	65	76,1	394	265	3/4"	350	330	18	11	15	6
SD-M	80	88,9	519	390	3/4"	470	450	25	16	20	16
SD-M	100	114,3	519	353	3/4"	475	455	28	19	30	16
SD-M	125	139,7	710	454	3/4"	635	615	46	36	50	50
SD-M	150	168,3	710	454	3/4"	635	615	50	39	75	50
SD-M	200	219,1	909	623	1"	775	745	72	60	125	95
SD-M	250	273,0	1139	840	2"	890	860	140	120	200	190
SD-M	300	323,9	1469	1095	2"	1005	975	209	184	275	275

* Flow rates when velocity is 1 m/s.

Note : Virra, reserves the right to modify dimensions, material and design without warning.

Installations

VIRACLEAN Dirt Separator should always be installed before equipment (ie. boilers, chillers, controll valves, pumps, etc.) That needs protection from dirt, sludge, etc.

In heating systems this should be in the return.

In chilled water systems the unit must be located in the return close to the chiller.

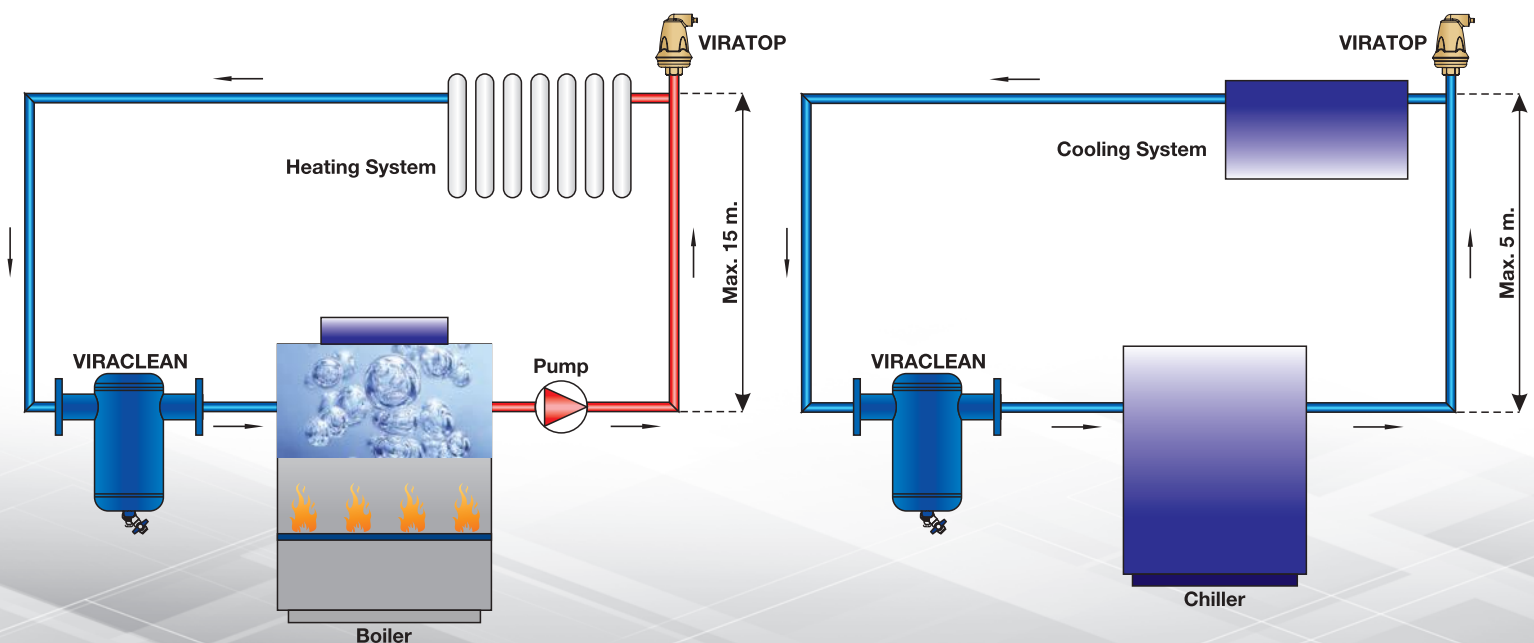

MAGNETIC VIRAPLUS

DEAERATOR AND DIRT SEPARATOR

TYPE : SC-M

DN 50 - 600



Features

Body	: Carbon Steel - ST37
Connections	: Flanged - Welded End - Grooved
Max. Working Temperature	: 110 °C
Max. Working Pressure	: 10 bar
Strainer Screen	: Stainless Steel
Product Range	: SC-F-M Flanged SC-K-M Welded End SC-V-M Grooved
Size	: DN 50 - DN 600

Applications

Today's highly energy-efficient heating and cooling systems offer optimal performance with water that is free of air and dirt. In untreated systems, air may cause problems such as flow interruptions or even a complete system breakdown. Dirt consists mainly of magnetite, that can accumulate wherever a magnetic field is present. In valves, for example, or heat exchangers, pipes, radiators, pumps and calorimeters. Next to costs associated with repairs, parts and downtime, contamination also leads to reduced system performance and, therefore, higher energy costs.

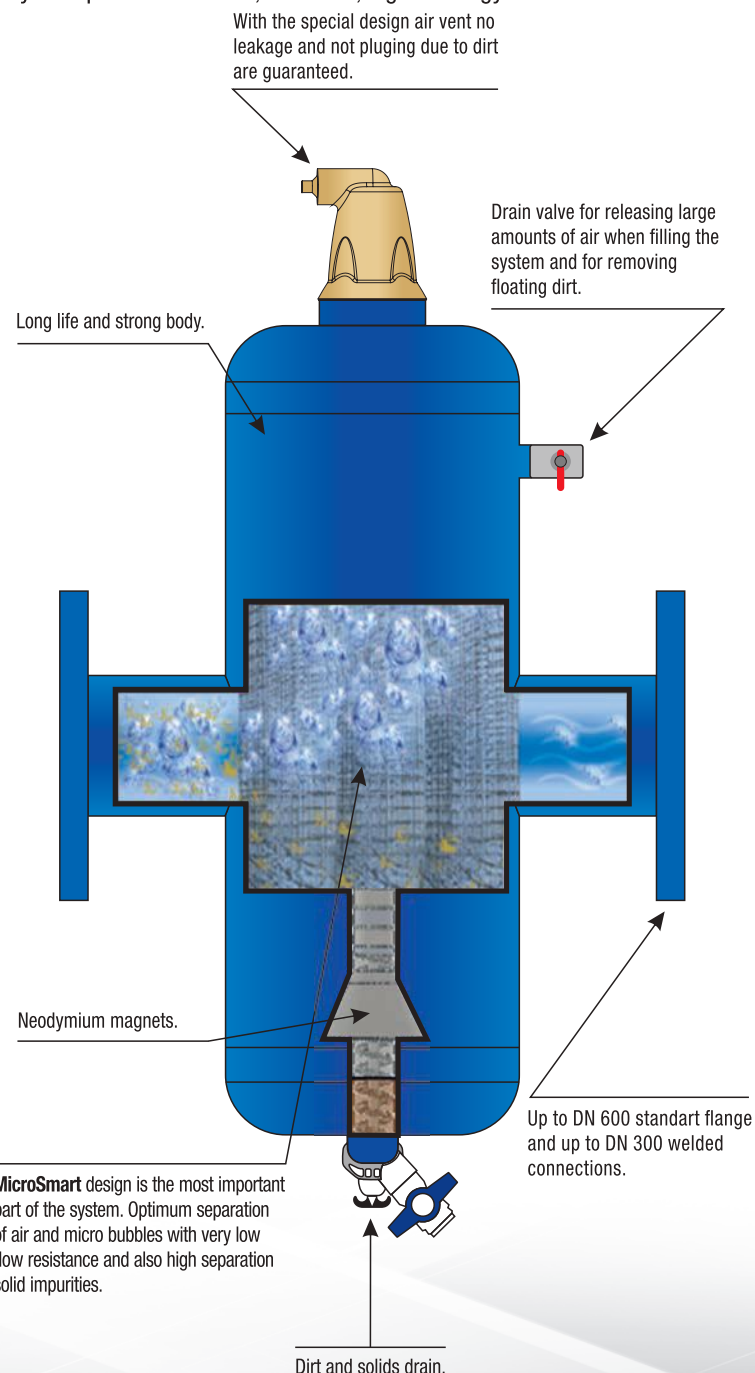

Technical Features

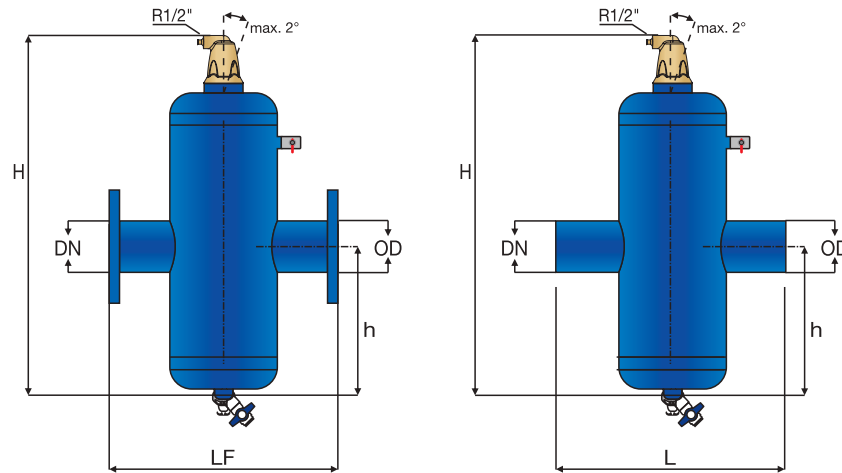

TYPE	DN	OD	H	h	e	LF	L	Flanged Weight	Welded Weight	Flow*	Volume
		mm	mm	mm	inch	mm	mm				
SC-M	50	60,3	641	265	3/4"	350	330	18	14	8	10
SC-M	65	76,1	641	265	3/4"	350	330	22	14	15	10
SC-M	80	88,9	800	345	3/4"	470	450	29	24	20	24
SC-M	100	114,3	800	345	3/4"	475	455	32	25	30	24
SC-M	125	139,7	1073	480	3/4"	635	615	55	47	50	70
SC-M	150	168,3	1073	480	3/4"	635	615	83	69	75	70
SC-M	200	219,1	1316	615	1"	775	745	105	89	125	140
SC-M	250	273,0	1587	815	2"	890	860	155	134	200	265
SC-M	300	323,9	1911	1120	2"	1005	975	232	206	275	465

* Flow rates when velocity is 1 m/s.

Note: Vira, reserves the right to modify dimensions, material and design without warning.

Installations

VIRAPLUS is a combination of deaerator and dirt separator which removes circulating air and micro bubbles also dirt effectively. In heating systems the Viraplus should be in the flow and installed after the boiler

In chilled water systems the unit must be located in the return close to the chiller.

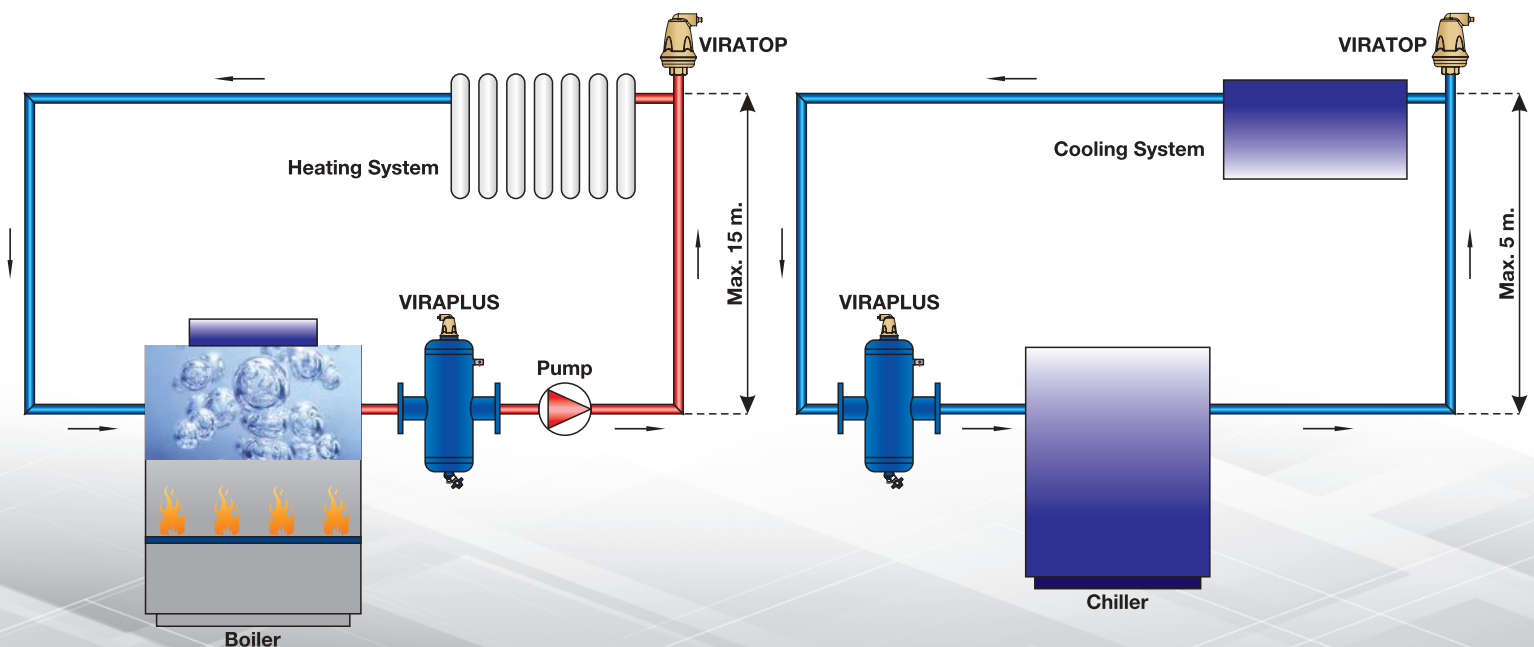

MAGNETIC VIRAFIX

DEAERATOR, DIRT AND HYDRAULIC SEPARATOR

TYPE : SCX-M

DN 50 - 600



Features

Body	: Carbon Steel - ST37
Connections	: Flanged - Welded End - Grooved
Max. Working Temperature	: 110 °C
Max. Working Pressure	: 10 bar
Strainer Screen	: Stainless Steel
Product Range	: SCX-F-M Flanged SCX-K-M Welded End SCX-V-M Grooved
Size	: DN 50 - DN 600

Applications

Increasingly, heating installations are fitted with several boilers. As a result, individual boilers can be switched on or off, depending on the heating requirements. In addition, there are often multiple sub-systems fitted with individual pumps. With these systems there is a chance of hydraulic imbalance which will lead to poor heat transfer, overloading of pumps and a system that is difficult to stabilize. Using a Virafix hydraulic separator prevents this problem, separate micro bubbles and dirt very efficiently and improves the efficiency of the system.

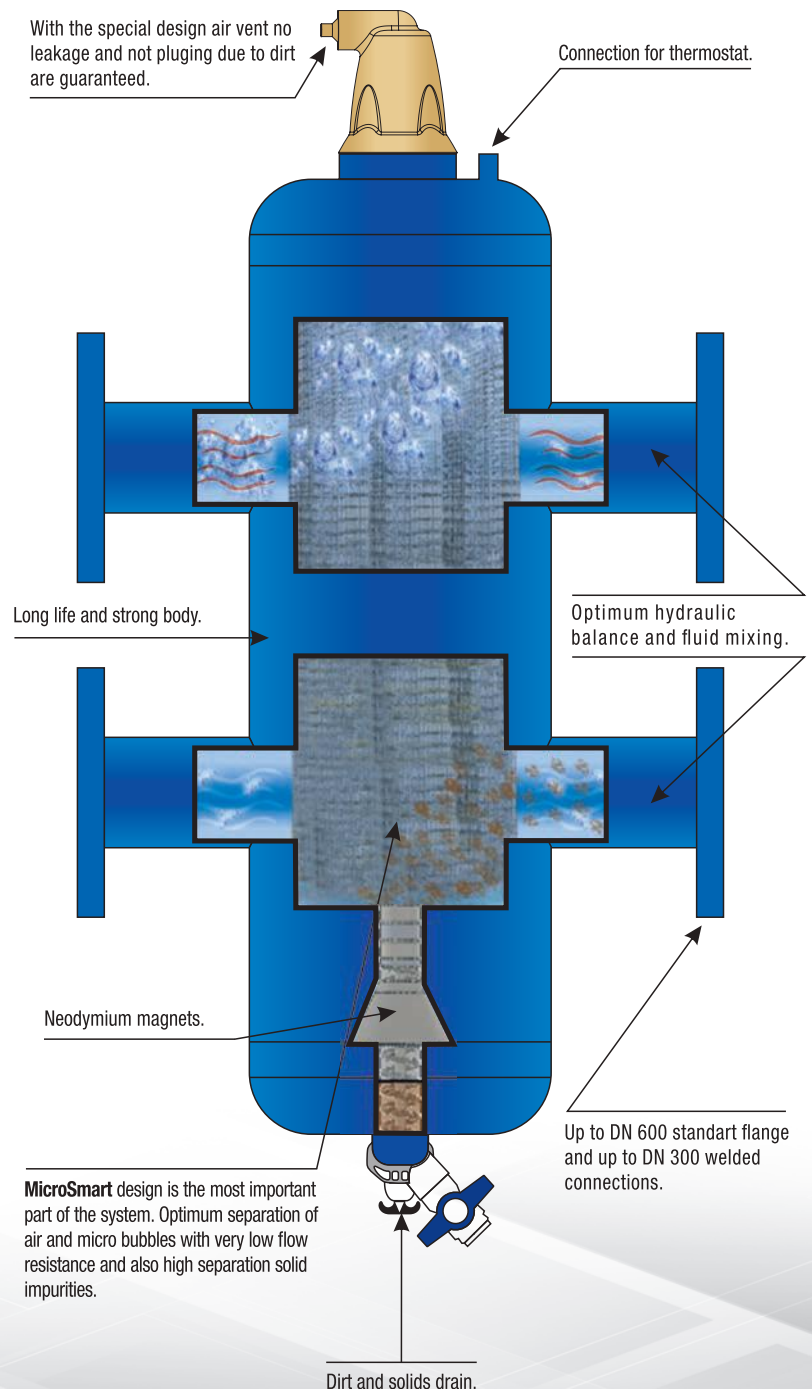

Technical Features

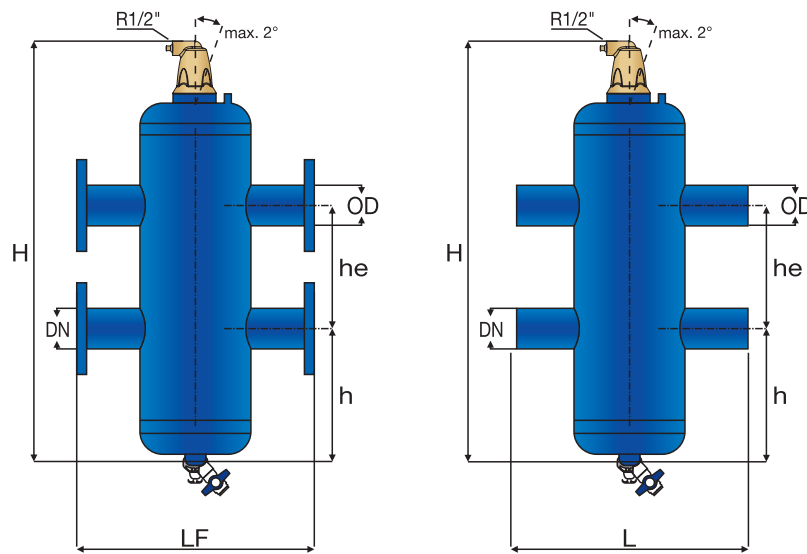

TYPE	DN	OD	H	h	he	e	LF	L	Capacity		Flow*
									($\Delta T=15^{\circ}\text{C}$)	($\Delta T=6^{\circ}\text{C}$)	
		mm	mm	mm	mm	inch	mm	mm	kW	kW	m ³ /h
SCX-M	050/150	60,3	821	248	240	3/4"	350	330	218	87	12,5
SCX-M	065/150	76,1	936	273	305	3/4"	350	330	349	140	20
SCX-M	080/200	88,9	991	273	360	3/4"	470	450	471	188	27
SCX-M	100/200	114,3	1241	348	462	3/4"	475	455	820	328	47
SCX-M	125/300	139,7	1541	448	560	3/4"	635	615	1256	502	72
SCX-M	150/300	168,3	1841	543	670	3/4"	635	615	1884	753	108
SCX-M	200/400	219,1	2345	695	870	3/4"	775	745	3143	1256	180
SCX-M	250/500	273,0	2895	860	1100	2"	890	860	5023	2009	288
SCX-M	300/600	323,9	3411	1020	1295	2"	1005	975	7064	2826	405

* Flow rates when velocity is 1,5 m/s.

Note : Vira, reserves the right to modify dimensions, material and design without warning.

Installations

Installation of a hydraulic separator in a heating system provides proper mixing, when flow in the boiler circuit is different from flow in the distribution circuit. Also VIRAFIX is a combination of deaerator, dirt separator and hydraulic separator which removes circulating air and micro bubbles also dirt effectively.

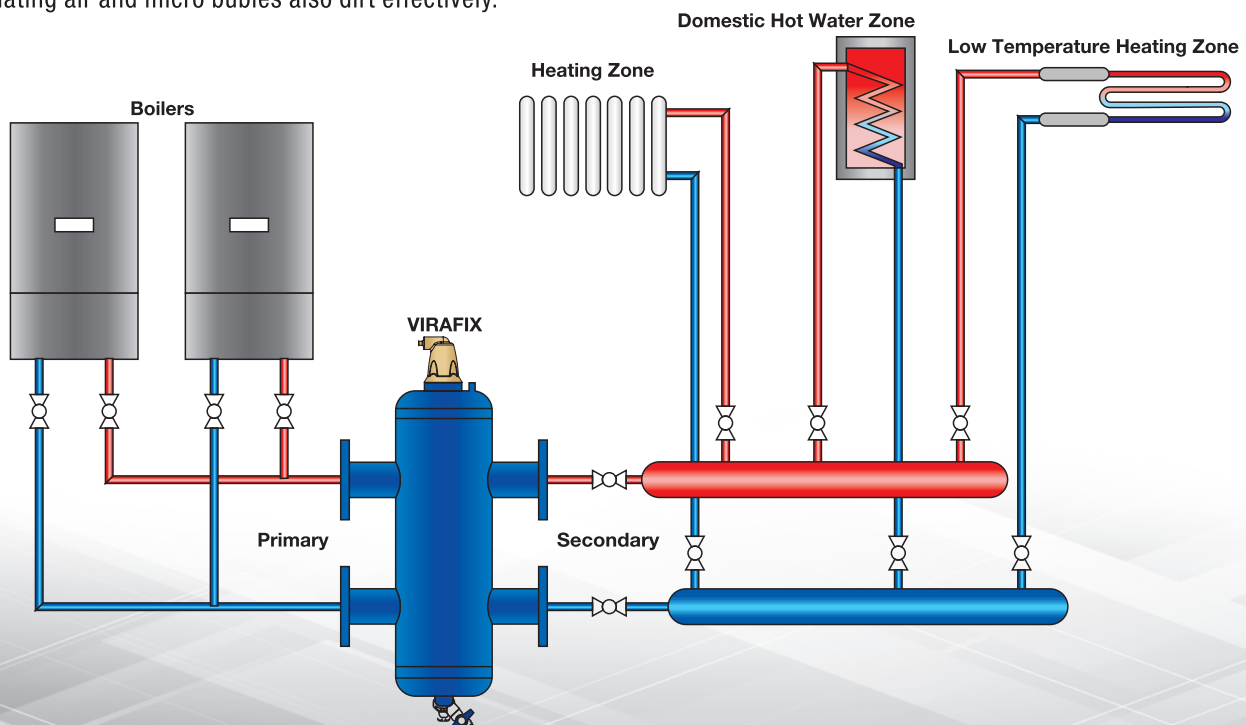

VIRADOSING

CHEMICAL DOSING POTS

TYPE : VDK

5 lt. - 50 lt.



Features

Vessel	: Stainless Steel
Tundish	: Stainless Steel
Flow / Return Valve	: 1" Stainless Steel
Drain Valve	: 1" Stainless Steel
Max. Working Pressure	: 10 bar
Max. Working Temperature	: 90 °C

Applications

The Vira range of dosing pots provides a safe, controlled method of dosing chemicals into heating and chilled water systems with no interruption to the system operation.

Vira dosing pots are supplied as a complete package with all valves and tundish fitted to minimise time on site for installation. These cost effective, easy to install units facilitate simple, regular on-going maintenance of your heating or chilled water system.

For your safety, each Vira dosing pot is fitted with an integral safety valve that prevents fluid escaping under pressure if the top entry valve is opened before the flow and return valves are closed. Also, for your peace of mind, each unit is individually hydrostatically tested to 16 bar prior to despatch.

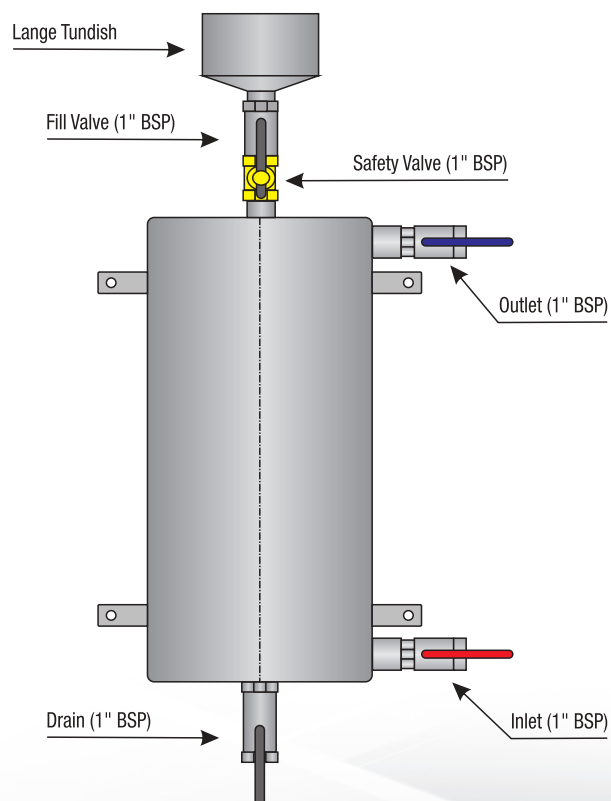

Technical Features

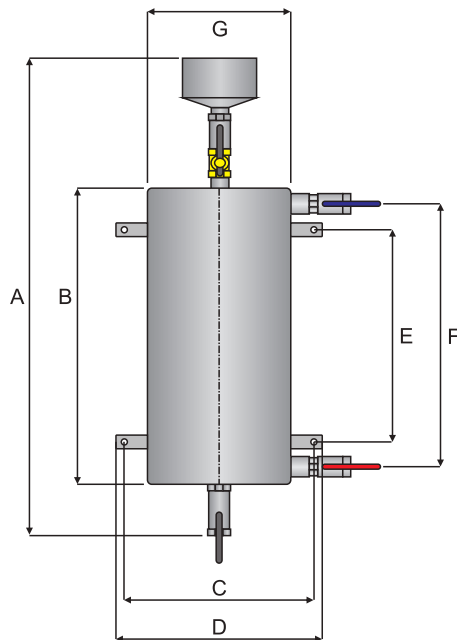

SIZE	CODE	DIMENSIONS (mm)						
		A	B	C	D	E	F	G
5	VDK 5	900	300	200	250	100	180	168
10	VDK 10	1100	500	200	250	300	380	168
15	VDK 15	1050	450	350	400	250	250	219
20	VDK 20	1200	600	350	400	400	400	219
25	VDK 25	1300	700	350	400	500	500	219

Installations

For correct operation of the unit follow the instructions and diagram below. Where multipledosing is required, repeat the steps as necessary until correct system concentration is achieved.

To ensure a fast, but safe dispersal of chemical dose, it is important that the unit is installed correctly.

Install the unit between the flow and return pipework at the point with the highest differential pressure.

Ensure the unit is securely fixed to a wall using the integral wall mounting brackets.

Make certain that the drainage point is either piped to waste or that there is suitable space beneath the unit for collection of discharged fluid.

ISOLATE THE UNIT

Close all Valves

DRAIN THE UNIT

Open the drain valve first, followed by the fill valve.

FILL THE UNIT

Close the drain valve and pour dosing chemical in to the unit through the tundish.

BEGIN DOSING

Fully open the inlet and outlet valves slowly.

COMPLETE DOSING

Close all valves when dosing has completed. Repeat the above steps if necessary.

SIZING

This selection can be used for heating and cooling systems.

For optimum results, a flow velocity should be less than 1,5 m/s. Above 1,5 m/s flow velocities will affect the Smartvent deaerators and dirt separators' ability to eliminate air. Two examples for different installation place possibilities :

A) If the installation place is low pressure and high temperature, the velocity should be 1,5 m/s.

1. From the 'Flow' axis at 70 m³/h at point A, move vertically to the 1,5 m/s water velocity curve at point B.
2. Move left from point B to meet the "Smartvent Dimension" axis at point D.
3. Always choose the dimension that is the most nearest above the endpoint on the axis, for this example choose DN 125.

B) If the installation place is high pressure and high temperature, for example in the basement, the velocity should be 1 m/s.

1. From the 'Flow' axis at 70 m³/h at point A, move vertically to the 1 m/s water velocity curve at point C.
2. Move left from point C to meet the "Smartvent Dimension" axis at point E.
3. Always choose the dimension that is the most nearest above the endpoint on the axis, for this example choose DN 150.

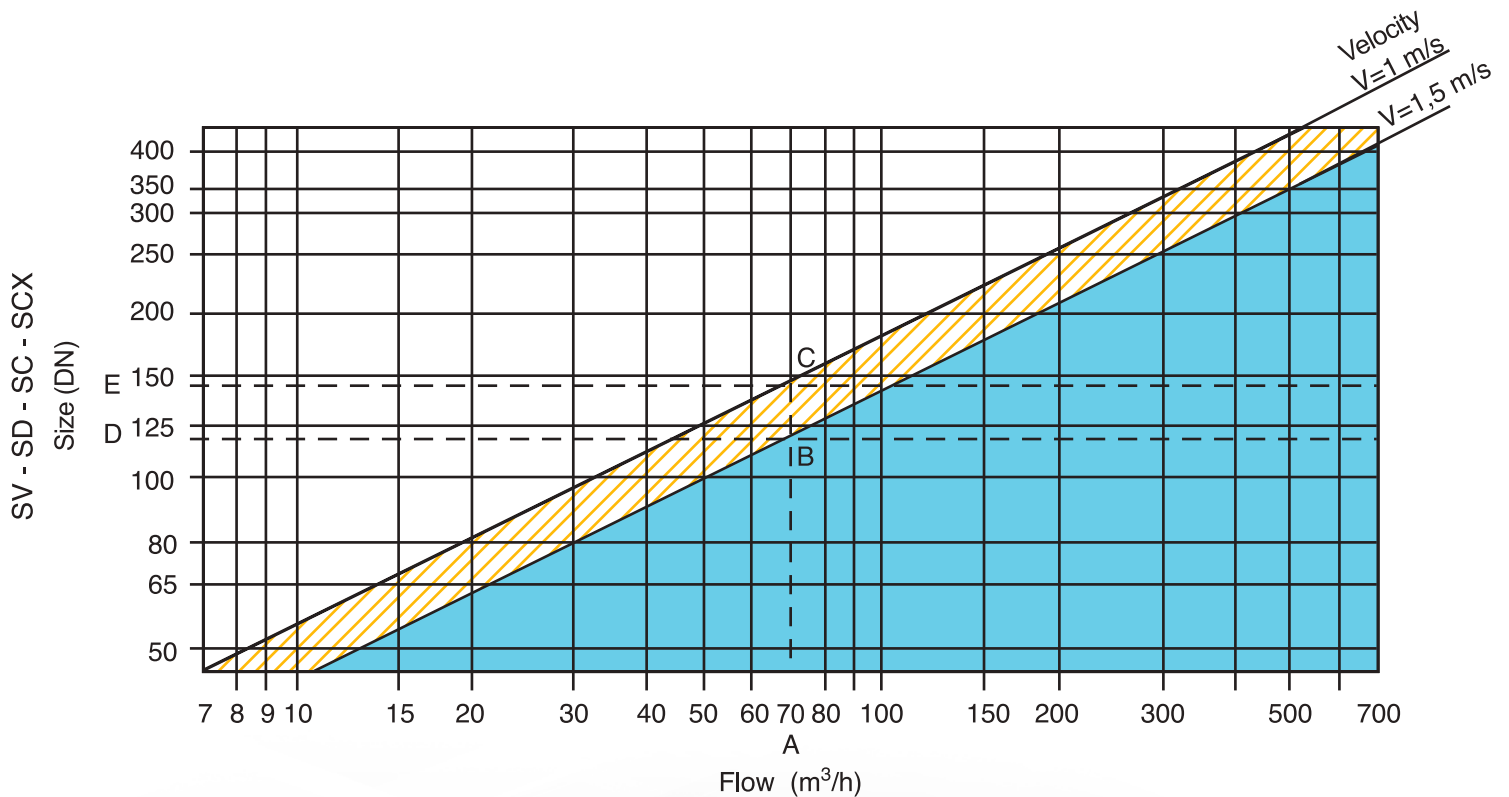

Resistance graph to flow various diameters of Smartvent Air and Dirt Separators as below.

BASINÇ KAYBI GRAFİĞİ (PRESSURE DROP CHART)

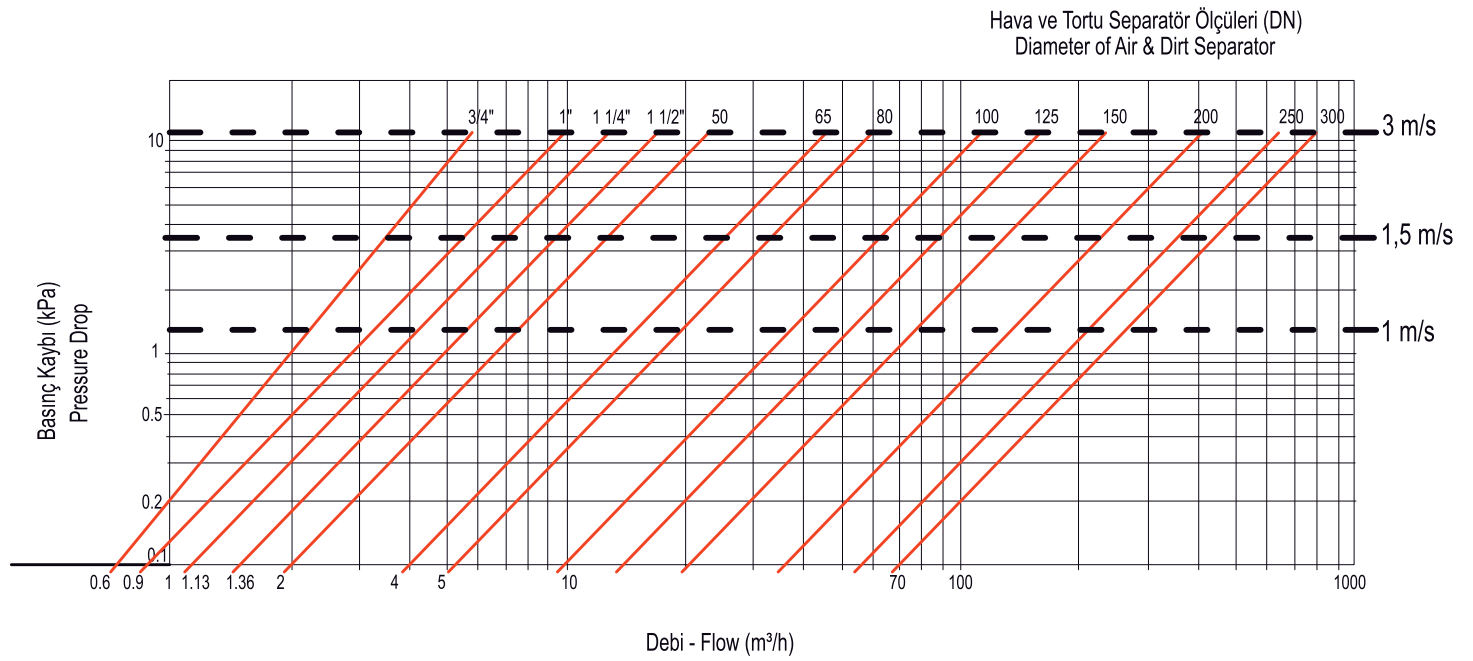

Example :

When the water flow is 70 m³/h pressure drop for the DN 150 Smartvent Air and Dirt Separators :

1. From the 'Flow' axis at 70 m³/h at point A, move vertically to the "Smartvent Dimension" DN 150 curve at point B.
2. Move left from point B to meet the "Pressure Drop" axis at point C, for this example Pressure Drop will be 1 kPa.

Vira products provide solutions to the problems.

Vira is a young, dynamic and expert company regarding production of separators, valves and steam related products. To meet our customers needs, we offer customers a combination of our application experience, on going technical support, correct installation and commissioning ability with our high quality products.

Vira provides durable, high-quality valves and steam related products that are used in many kinds of applications, from unique custom jobs to large scale installations.

- Automatic Air Vent
- Solar Automatic Air Vent
- Deaerators
- Dirt Separators
- Hydraulic Balance Tanks

- Butterfly Valves
- Ball Valves
- Check Valves
- Expansion Joints
- Safety Valves
- Actuators

- Steam Separators
- Condensate Pump
- Sample Coolers
- Steam Boiler Automation
- Automatic Blowdown Systems
- Steam Flow Meters
- Steam Traps

